

SHTABE

ROYAL 5038 эko

5038

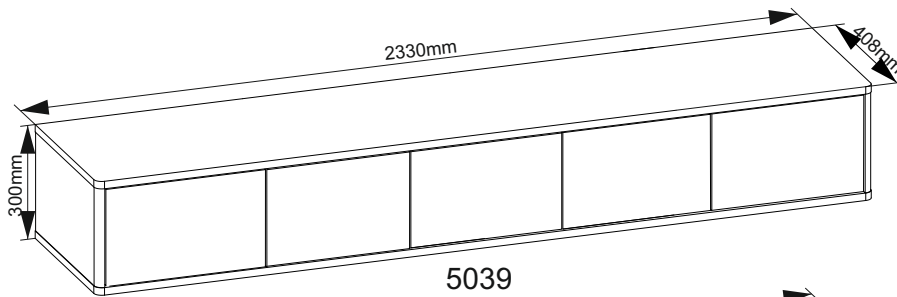

5039

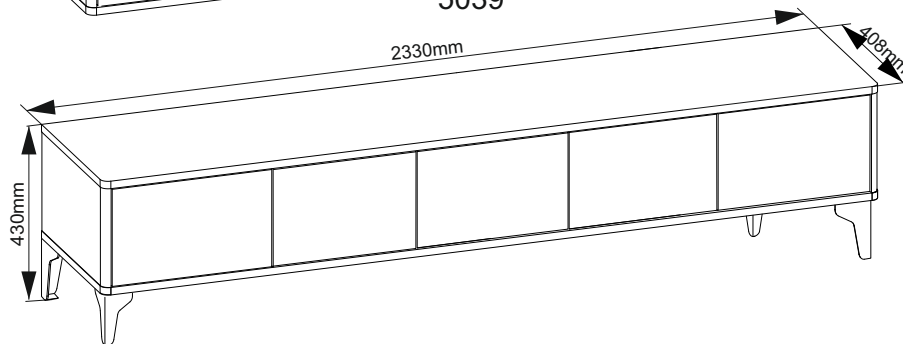

ТЕХПОДДЕРЖКА

DEUTSCH Fachkundige Montage erforderlich. Unsachgemäße Montage kann zu Unfällen führen. Da es viele verschiedene Wandmaterialien gibt, sind Schrauben für die Wandbefestigung nicht beige packt. Erkundigen Sie sich ggf. beim Eisenwarenfachhandel nach geeignetem Befestigungsmaterial.

ENGLISH Assembly should be carried out by a qualified person, because wrong assembly may lead to that the furniture will topple over and cause injury or damage. As wall materials vary, screws for fixing to wall are not included. For advice on suitable screw systems, contact your local specialised dealer.

FRANÇAIS Le montage doit être effectué par une personne compétente. Un montage mal effectué peut provoquer la chute du meuble et blesser quelqu'un. Les vis et ferrures pour fixer le meuble au mur ne sont pas incluses. Choisissez des vis et ferrures adaptées au matériel de votre mur. En cas de doute, demandez conseil à un vendeur spécialisé.

ITALIANO Il montaggio deve essere effettuato da una persona competente. Se non viene effettuato correttamente, il prodotto può ribaltarsi o cadere, danneggiando persone o cose. Poiché ci sono pareti di materiali diversi, le viti per il fissaggio alla parete non sono incluse. Per scegliere gli accessori di fissaggio adatti, rivolgeti a un rivenditore locale.

ESPAÑOL Mantaje a realizar por montador autorizado, pues un montaje erróneo puede resultar en una caída del mueble, causando daños a personas o cosas. Como hay muchas clases de materiales de pared, no se incluye los tornillos de montaje. Para sugerencias sobre sistemas de colocación adecuados, ponte en contacto con tu especialista más cercano.

PORTUGUES A montagem deverá ser realizada por uma pessoa qualificada, pois uma montagem incorreta pode povocar a queda do móvel e causar lesões ou estragos. Como os materiais de parede variam, os parafusos para fixar à parede não estão incluídos. Para mais conselhos sobre o sistema de parafusos adequado, consulte o seu retalhista local especializado.

NEDERLANDS De montage dient te worden uitgevoerd door een vakbekwaam iemand. Foutieve montage kan ertoe leiden dat het meubel omvalt, waardoor er persoonlijk letsel of schade kan ontstaan. Omdat er veel verschillende wandmaterialien bestaan, zit er geen wandbeslag bijgesloten. Voor advies over geschikt wandbeslag, neem contact op met de vakhandel.

SVENSKA Monteringen ska utföras av kunnig person, då felmontering kan leda till att möbelen faller och skadar någon eller något. Eftersom det finns många olika väggmaterial, medföljer ej skruvar för väggfästning. För råd om lämpliga skruvsystem, kontakta din lokala fackhandlare.

БЪЛГАРСКИ Необходим е монтаж от специалист. Неправилният монтаж може да причини злополуки. Тъй като има много различни стенини материали, винтовете за стенинен монтаж не са приложени. При нужда се информирайте в специализираните железарски магазини за подходящия крепежен материал.

SLOVENSKO Potrebna je strokovna montaža. Nepravilna montaža lahko vodi do nezgod. Ker obstajajo različni stenski materiali, vijaki za pritrditev na zidu niso priloženi. Za ustrezen pritrditveni material se po potrebi pozanimajte v strokovni trgovini z železarnino.

DANSK Monteringen skal udføres af en kyndig person, da fejlmontering kan føre til at møblet falder og skader nogen eller noget. Eftersom der findes mange forskellige vægmateriale, medfølger der ikke skruer til vægmontering. Ønsker du råd omkring forskellige skruestystemer, kontakt din lokale faghandler.

ČESKY Montáž by měla být provedena kvalifikovanou osobou – nesprávné provedení může vést k převrnutí nábytku a způsobit úraz nebo destrukci. Pro různé zdící materiály nejsou šroubky a uchycení obsaženy v balení. O vhodném připevnění se poradte s odborným prodejcem.

SLOVENSKY Montáž by mala byť prevedená kvalifikovanou osobou. Pri nesprávnej montáži môže dôjsť k pádu nábytku, a tým aj k prípadnému úrazu. Skrutky a úchytky na rôzne typy stien nie sú súčasťou balenia. Ak si nie ste istí, obráťte sa na kvalifikovanú osobu.

POLSKI Montaż powinien być przeprowadzany przez wykwalifikowaną osobę, ponieważ złe zmontowanie może spowodować zniszczenie mebla lub może wyrządzić szkodę domownikom. Ponieważ w każdym pomieszczeniu ściany mogą być wykonane z innego materiału, komplet nie zawiera żadnych wkrętów ani umocowań. Aby zasięgnąć porady w kwestii wyboru odpowiednich wkrętów skontaktuj się z lokalnym sklepem specjalistycznym.

MAGYAR Az összeszerelést ajánlatos képzett szakemberre bízni, mert a helytelen összeszerelés következtében a bútor felborulhat és sérülést okozhat. Mivel a fal anyaga lakásonként/otthononként eltérő lehet, a rögzítéshez szükséges csavarokat a csomag nem tartalmazza. A megfelelő csavar kiválasztásáért kérj tanácsot az áruházban a zakképzett személyzettől.

РУССКИЙ Сборка должна производиться специалистом, так как неправильная сборка может привести к опрокидыванию мебели, что может повлечь за собой ущерб или телесные повреждения. Так как материалы стен различаются, шурупы для фиксации к стене не прилагаются. Для выбора подходящих крепежных средств обратитесь в местный специализированный магазин.

ROMÂNĂ Necesită montaj de specialitate. Montarea necorespunzătoare poate cauza accidente. Deoarece există multe materiale diferite pentru pereți, șuruburile pentru fixarea pe perete nu sunt incluse în ambalaj. Solicitați informații eventual de la magazinul specializat în articole de feronerie privind materialul de prindere adecvat.

HRVATSKI Potrebna stručna montaža. Nestručna montaža može dovesti do nesreća. Budući da postoje različiti zidni materijali, vijci za pričvršćenje na zid nisu uključeni. Raspitajte se npr. u željezariji o prikladnim materijalima za pričvršćenje.

TÜRKÇE Uzman kişilerce montaj yapılması gereklidir. Usulüne uygun yapılmayan montaj kazalara yolaçabilir. Çok sayıda duvar malzemesi olduğundan duvara sabitleme vidaları beraberinde verilmemiştir. İcabi halinde demirden yapılmış araç gereç satan dükkanlardan uygun sabitleme malzemeleri hakkında bilgi alın.

עברית מומלץ להרכיב את המוצר ע"י איש מקצוע. הרכבה לא נכונה עלולה לגרום לתאונות. עקב השוני בסוגי הקירות, ערכת ברגים לא מצורפת. לבחירת הברגים המתאימים יש להתייעץ עם בעל מקצוע.

Service • Dienstverlening • Serwis • Servis • Сервисная служба



ТЕХПОДДЕРЖКА

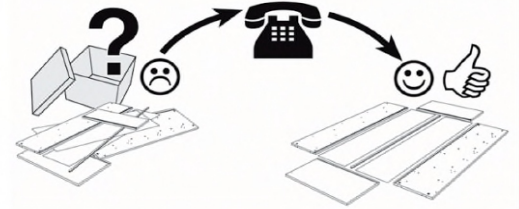
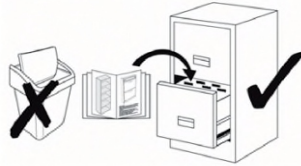

113	264	399	19	1x
114	264	399	19	1x
119	259	455	19	5x
127	340	200	16	8x
128	340	200	16	2x
129	264	370	16	2x
130	264	370	16	2x
140	409	186	16	2x
141	409	186	16	2x
142	400	186	16	2x
143	400	186	16	3x
152	426	338	3	2x
153	417	288	3	1x
154	460	273	3	2x
155	442	273	3	1x
164	400	186	16	1x
234	417	338	3	2x
237	273	446	3	1x
238	273	446	3	1x
239	2330	400	16	2x

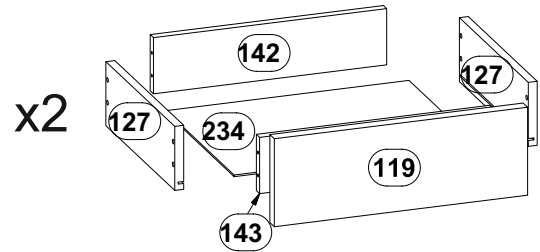
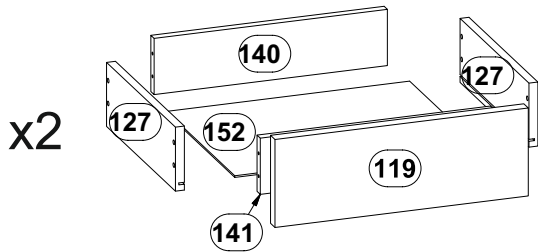
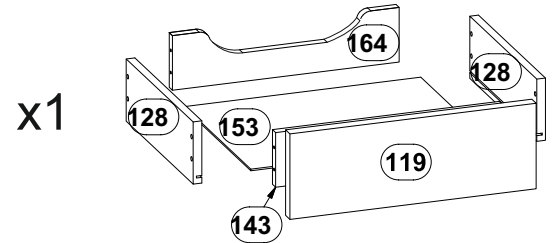
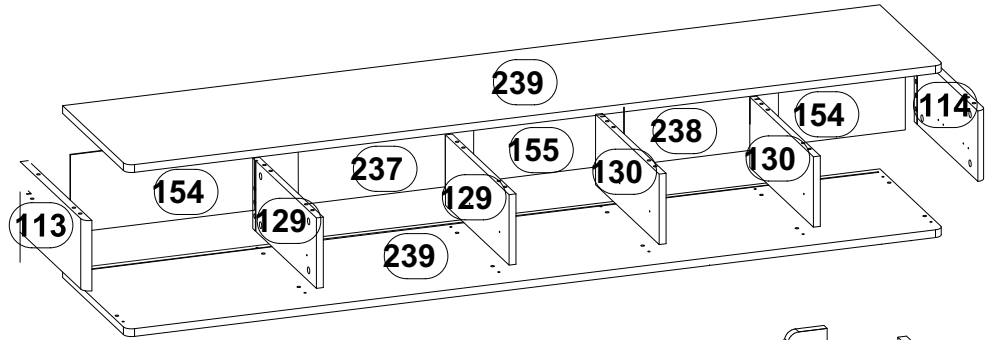

f1 x28	r1 x28	r42 x28	n101L x2	n101P x2	p51 x64	p1 x4
s2 x24	z1 x1	l2 x28	n174 x4	w117/3 x10	p21 x16	e1 x32
w117/L x4	w117/P x4	cb2 x1	cb1 x5			
w116/L x1	w116/P x1					

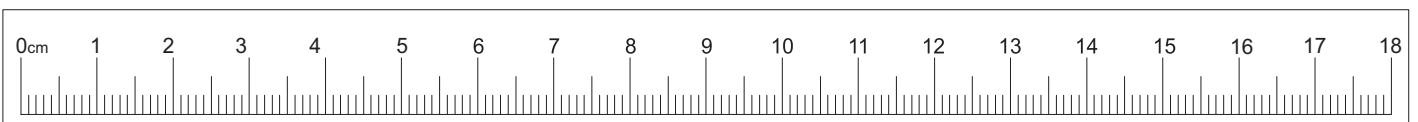

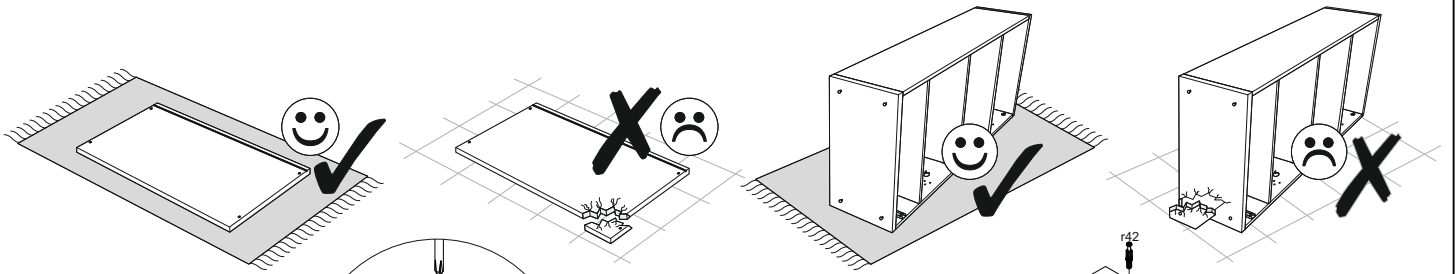

1

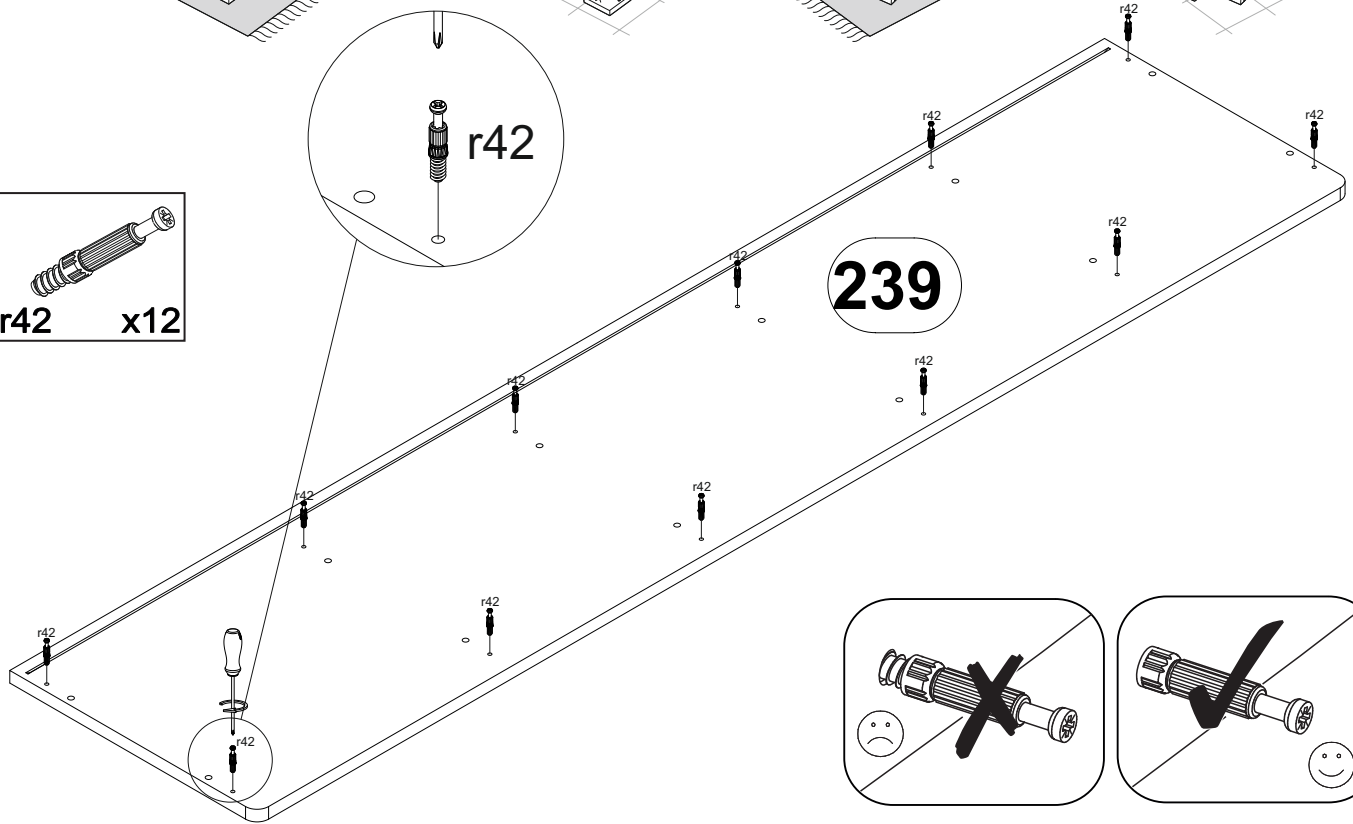
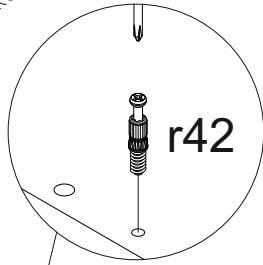
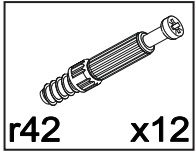

2

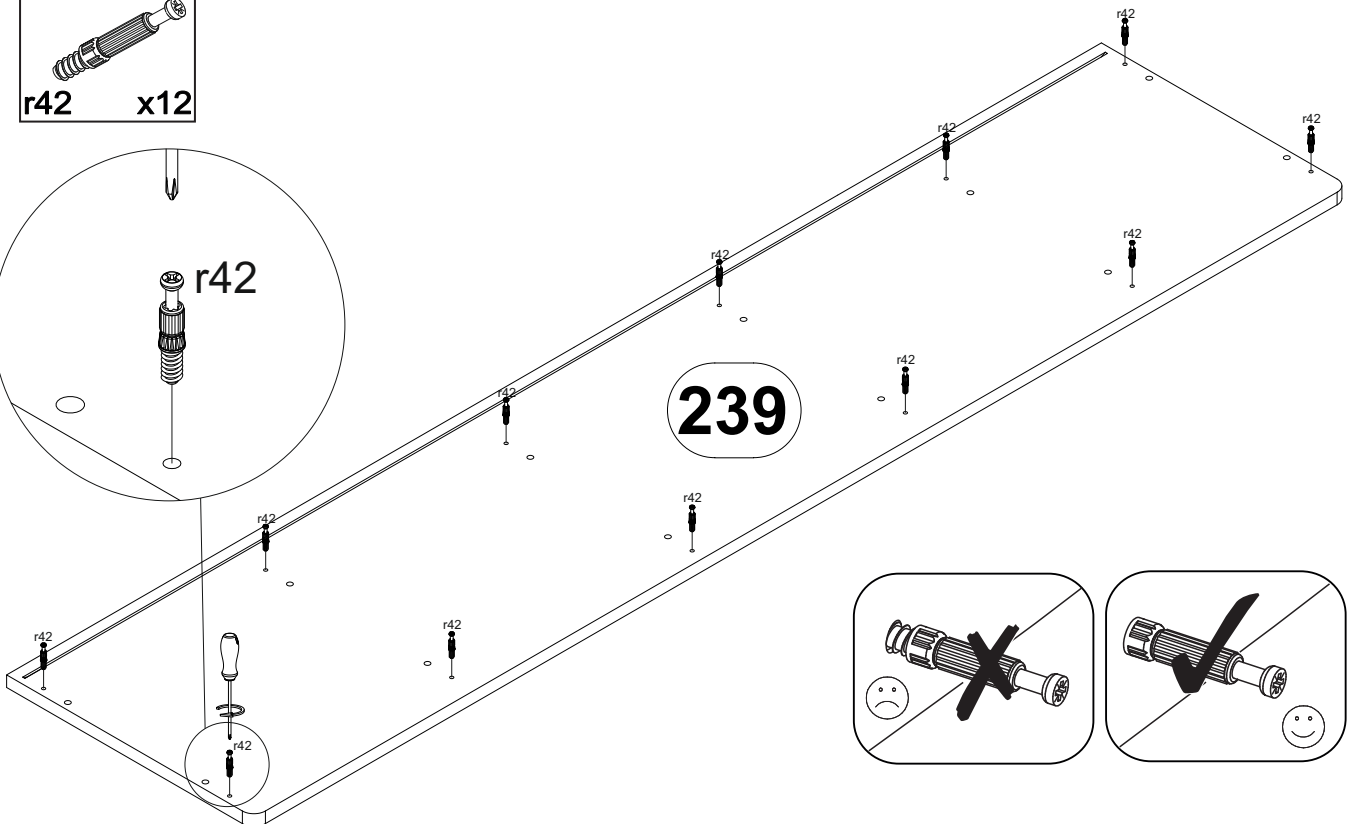
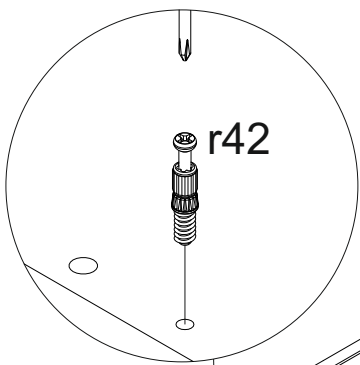
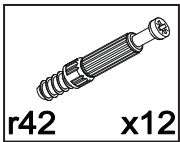

3

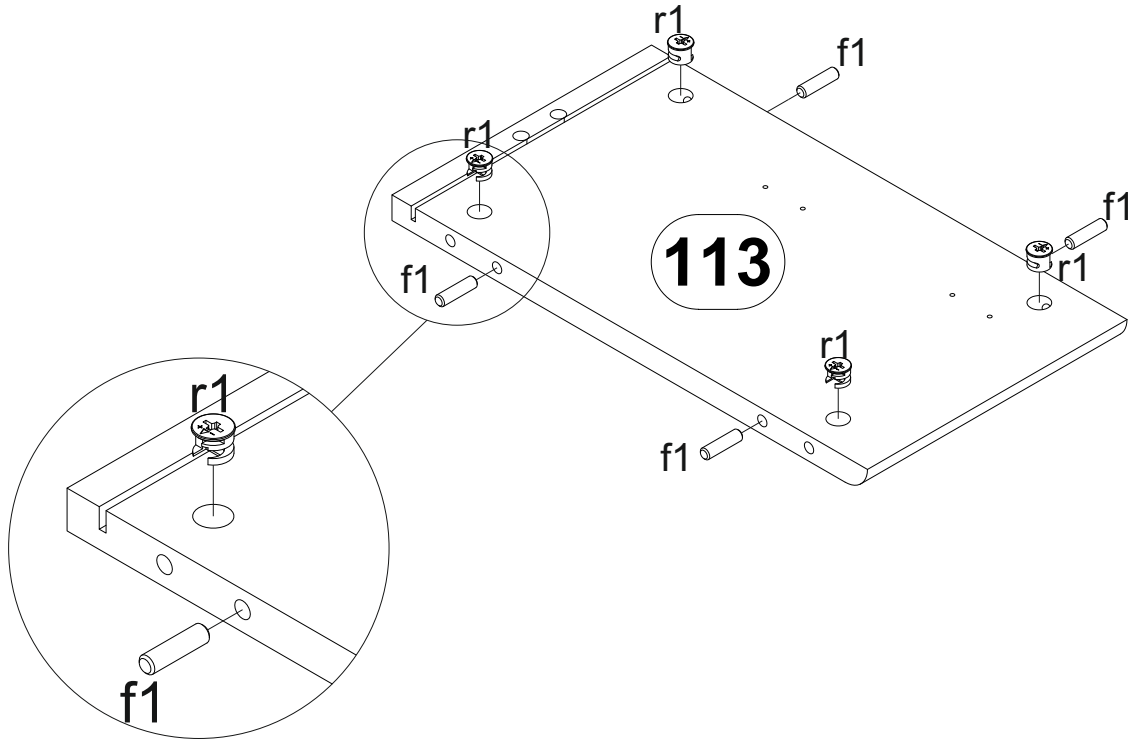
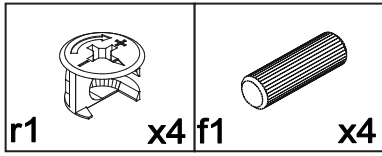

4

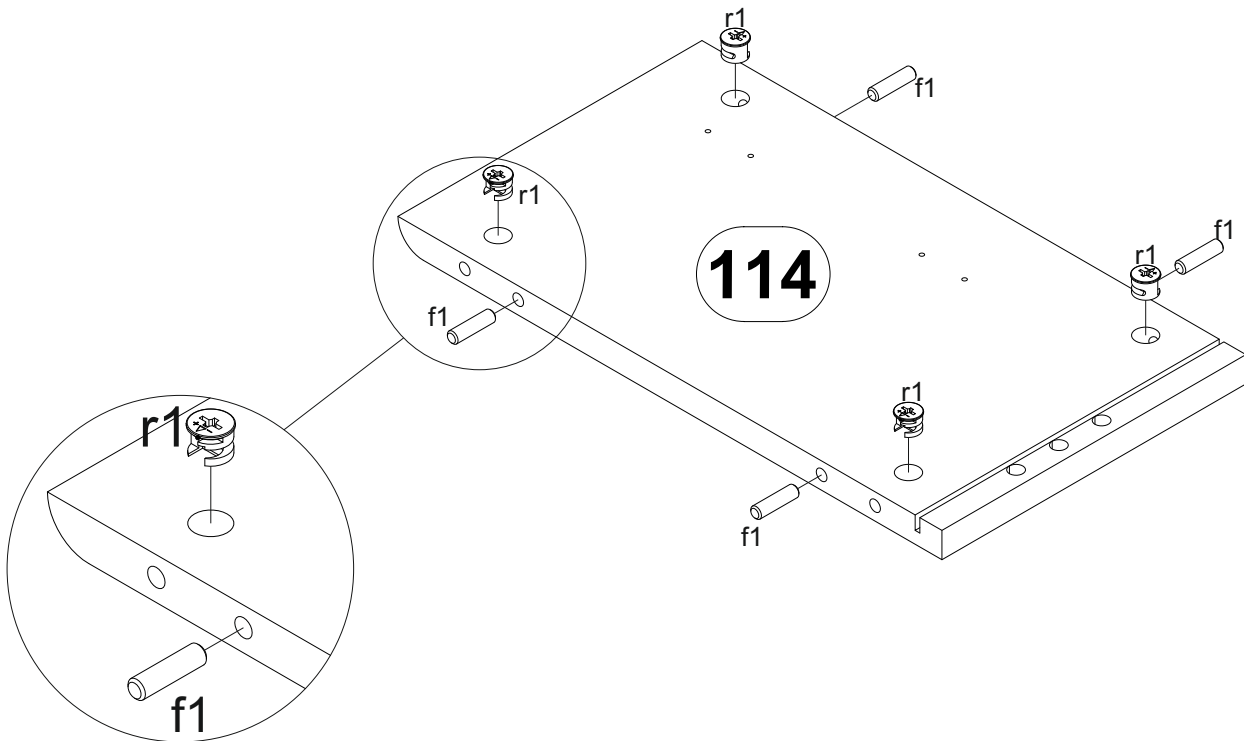
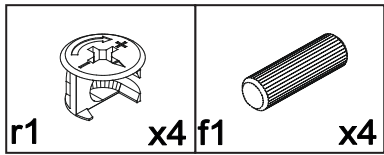

5

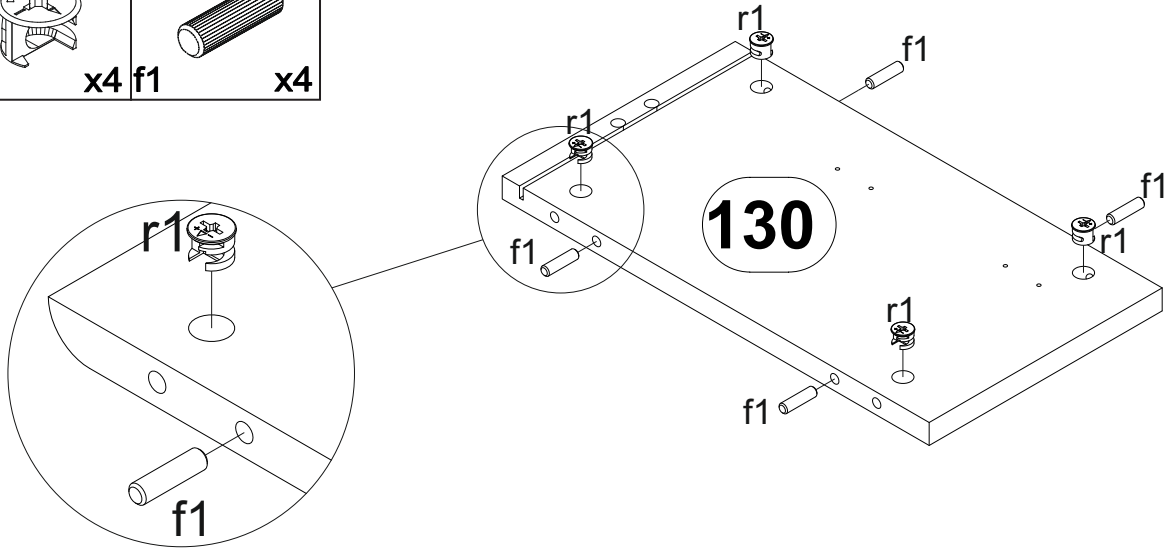
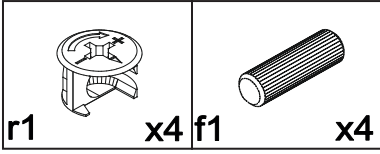

6

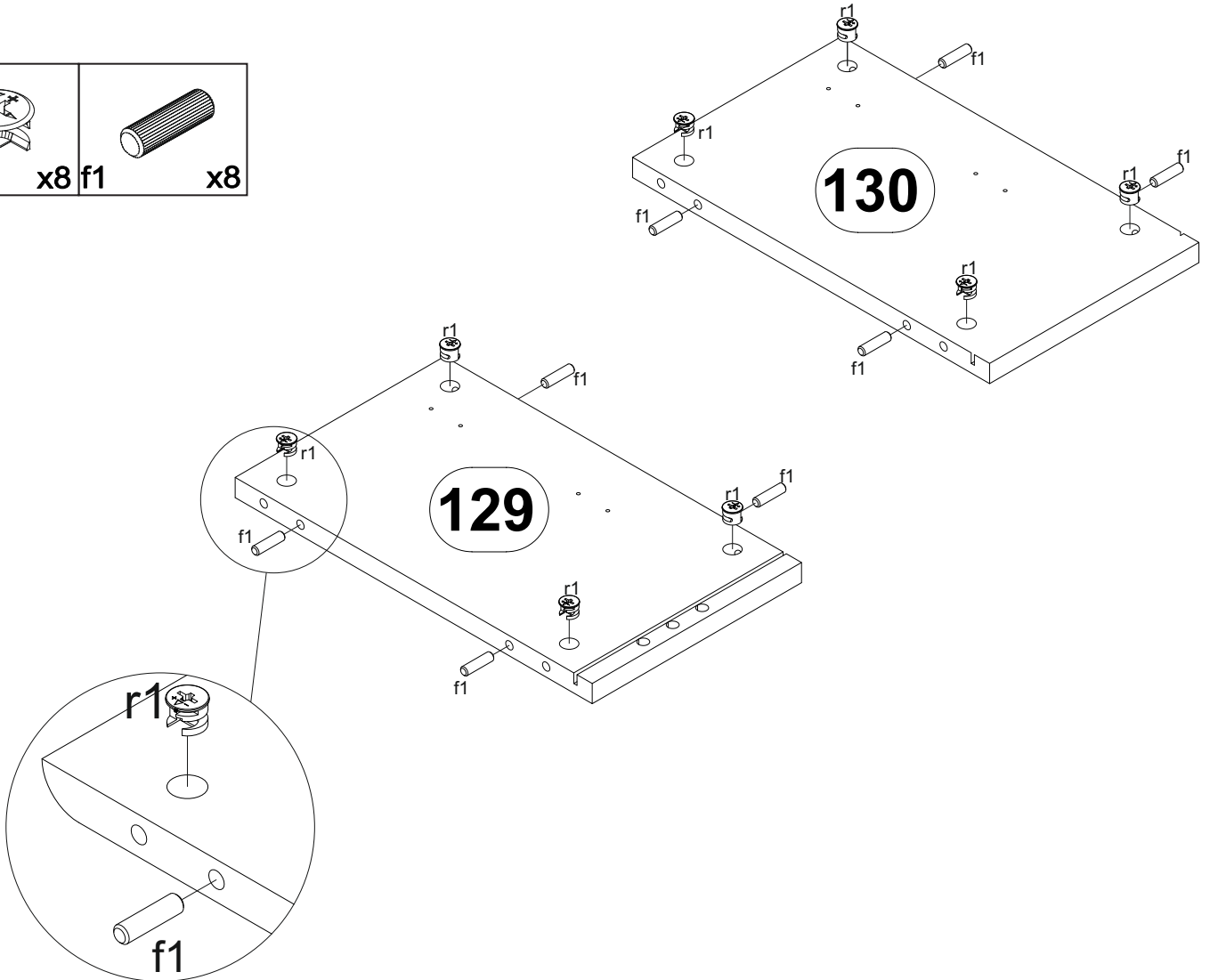
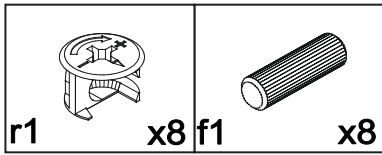

7

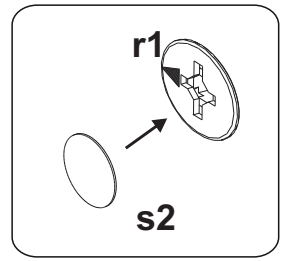
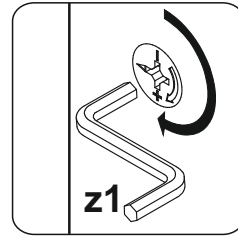
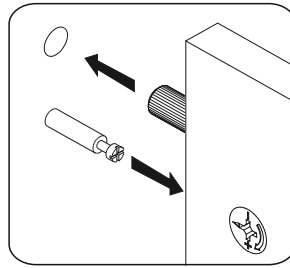
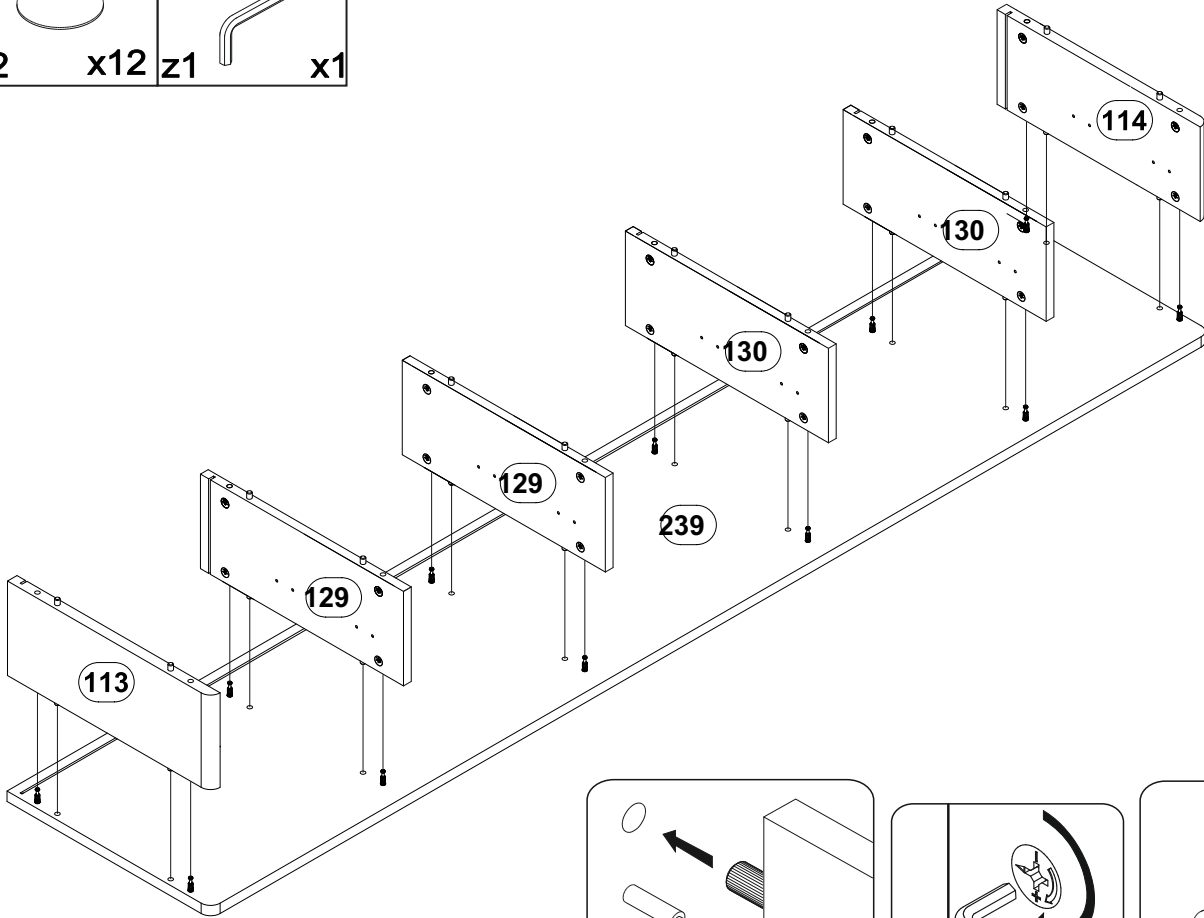
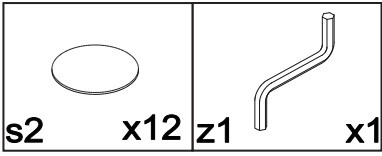

8

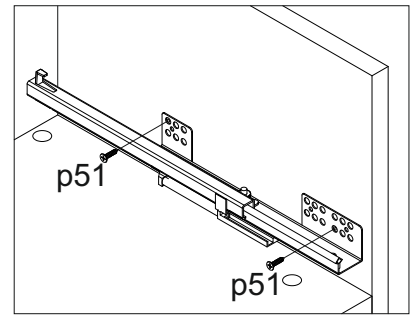
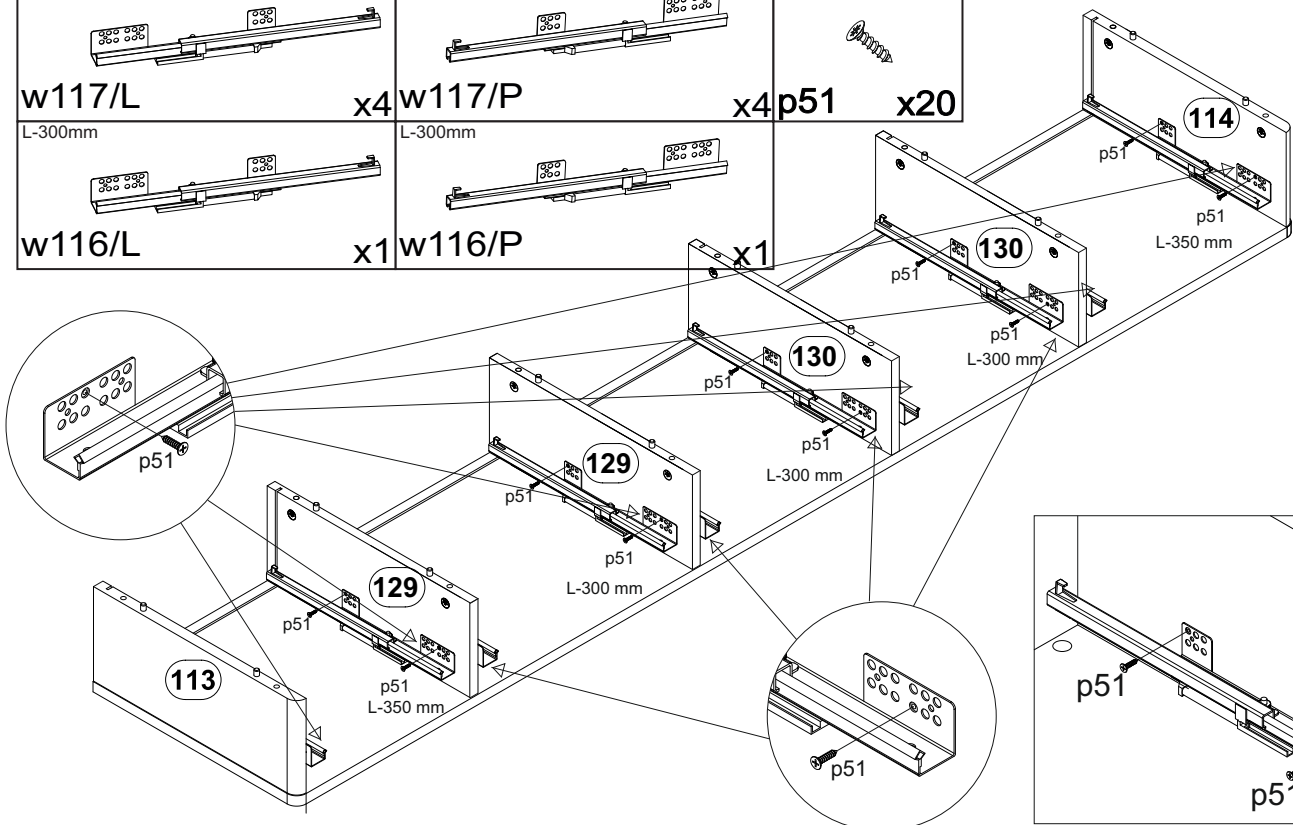
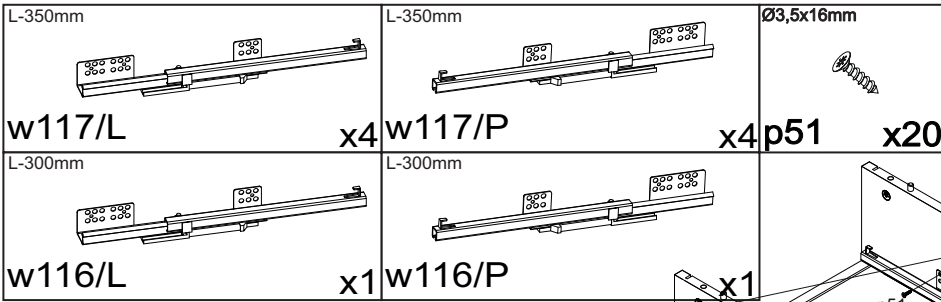

9

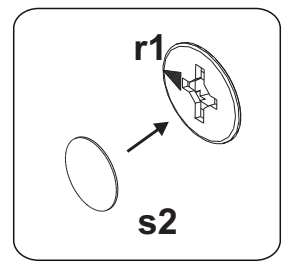
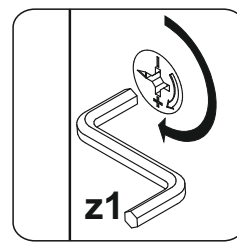
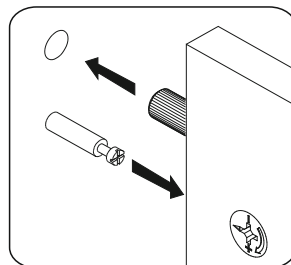
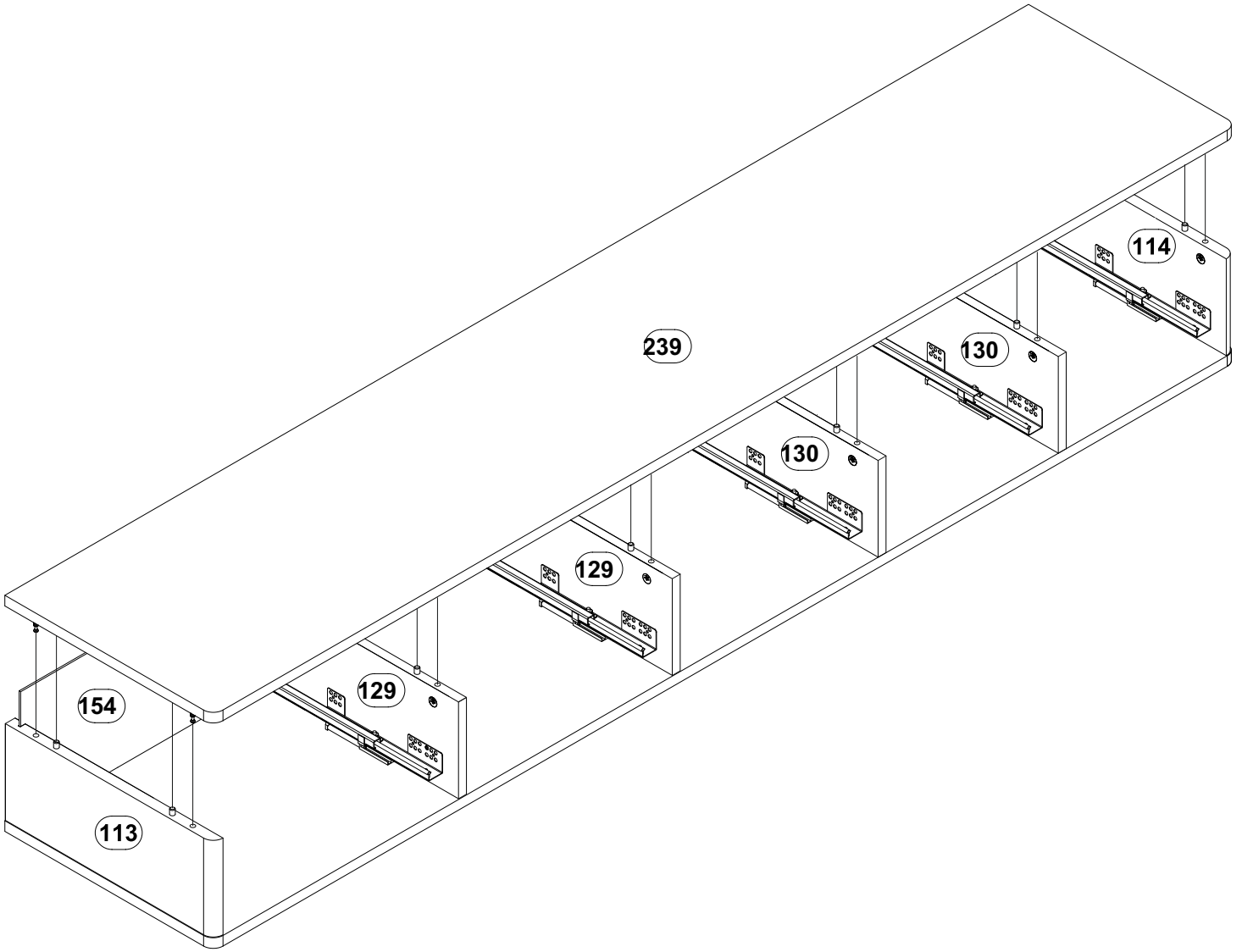
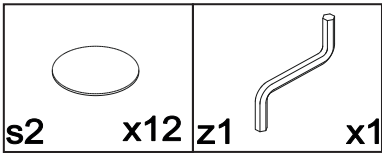

10

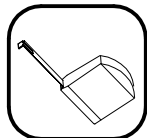
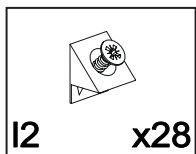

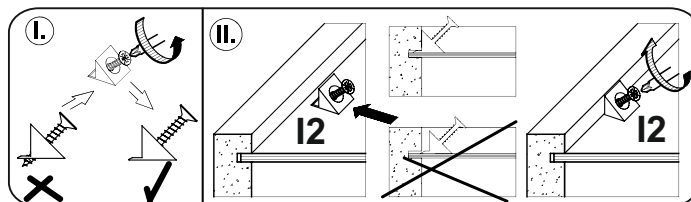
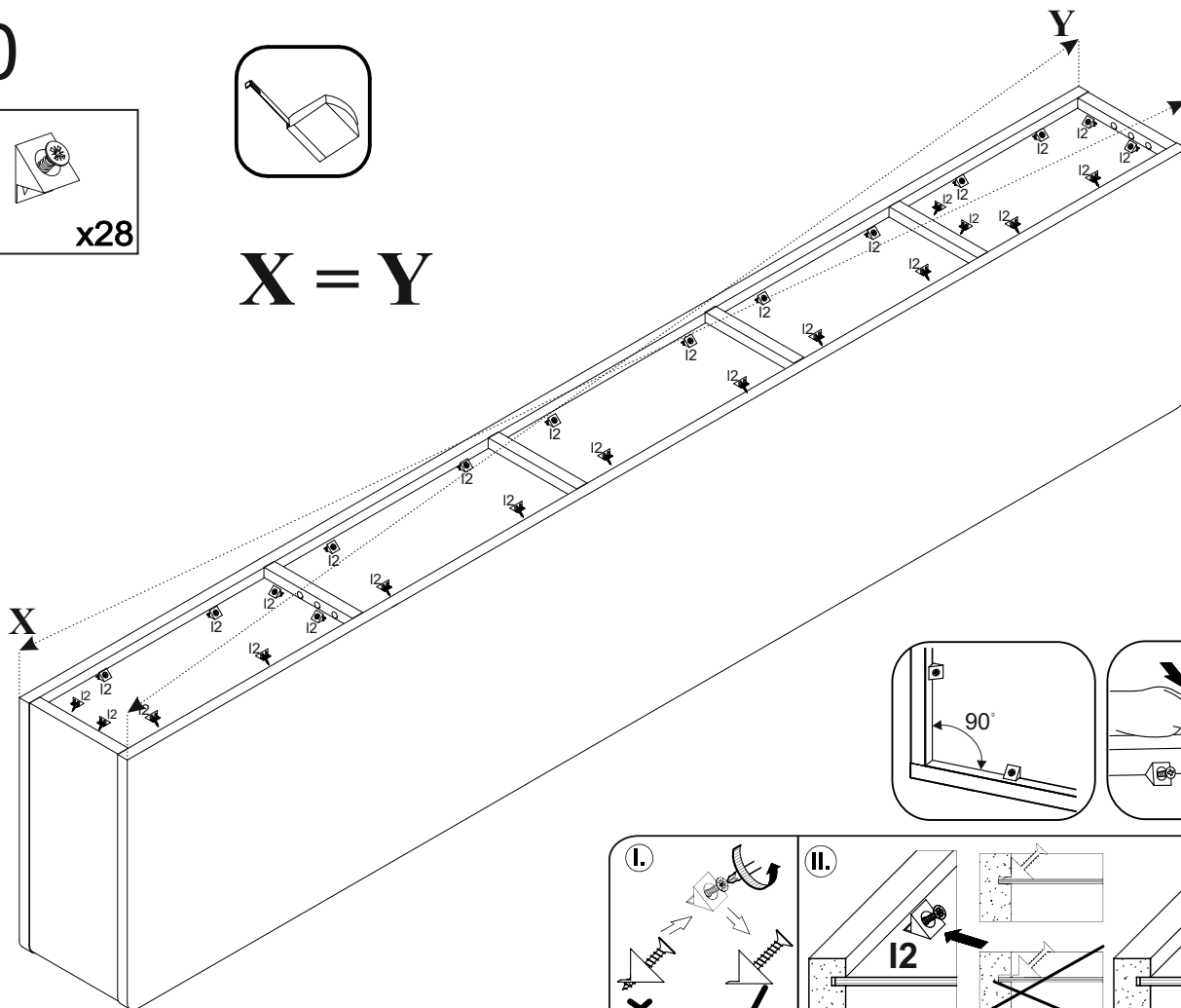

X = Y

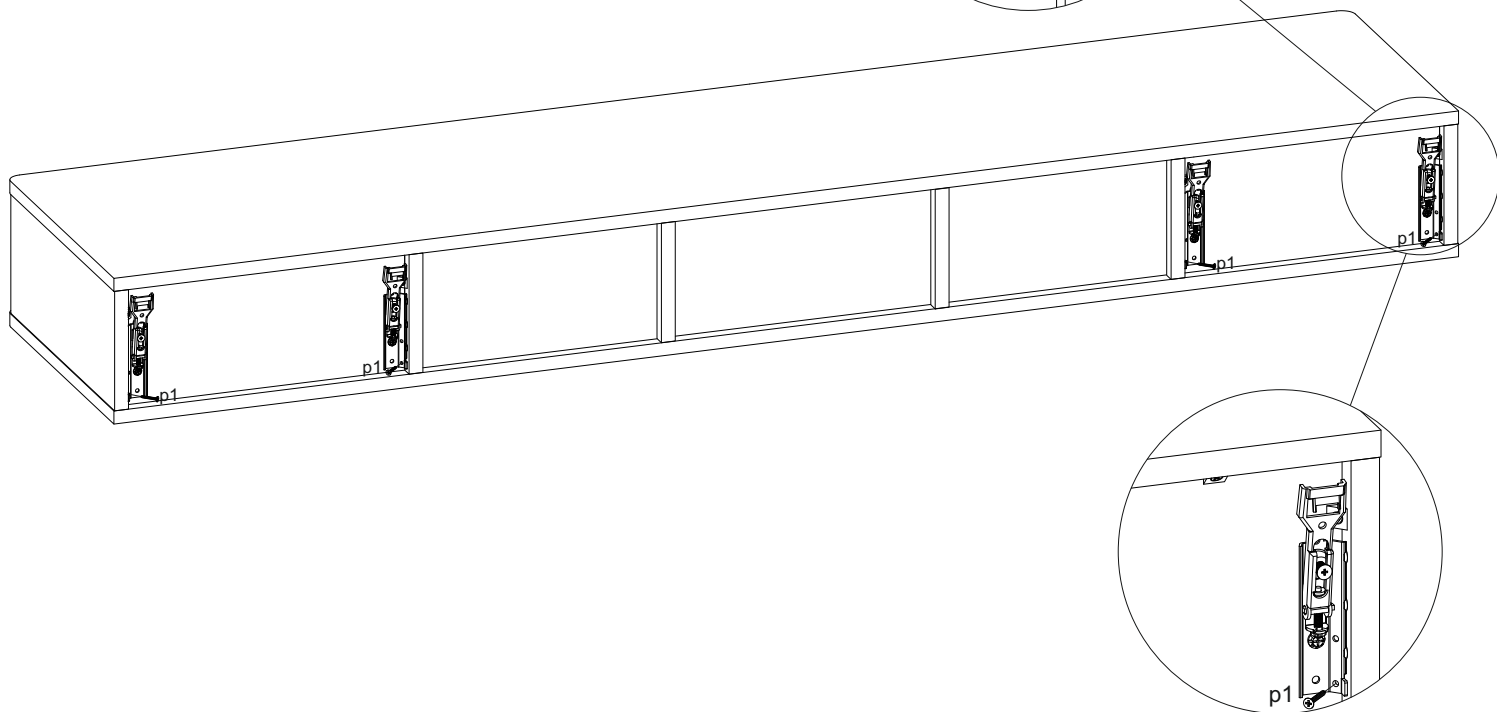
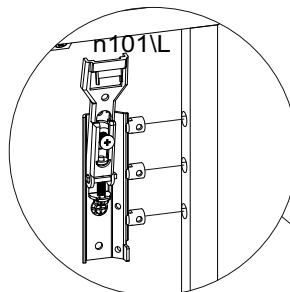
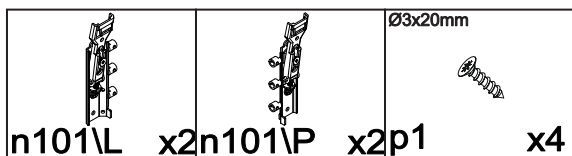

11



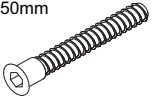
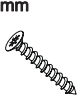

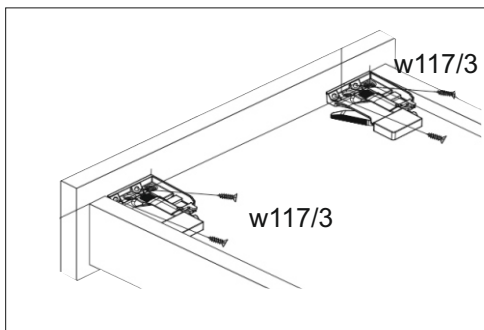
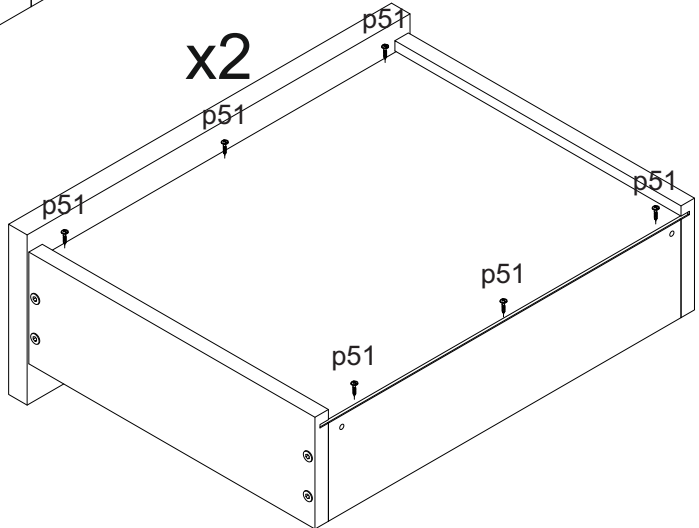
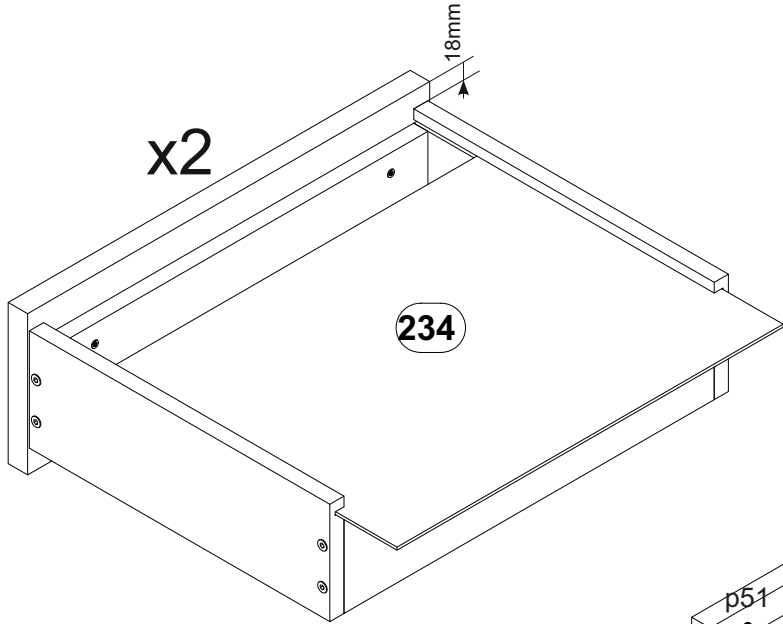
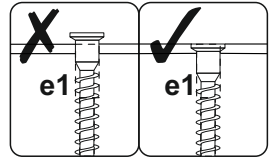
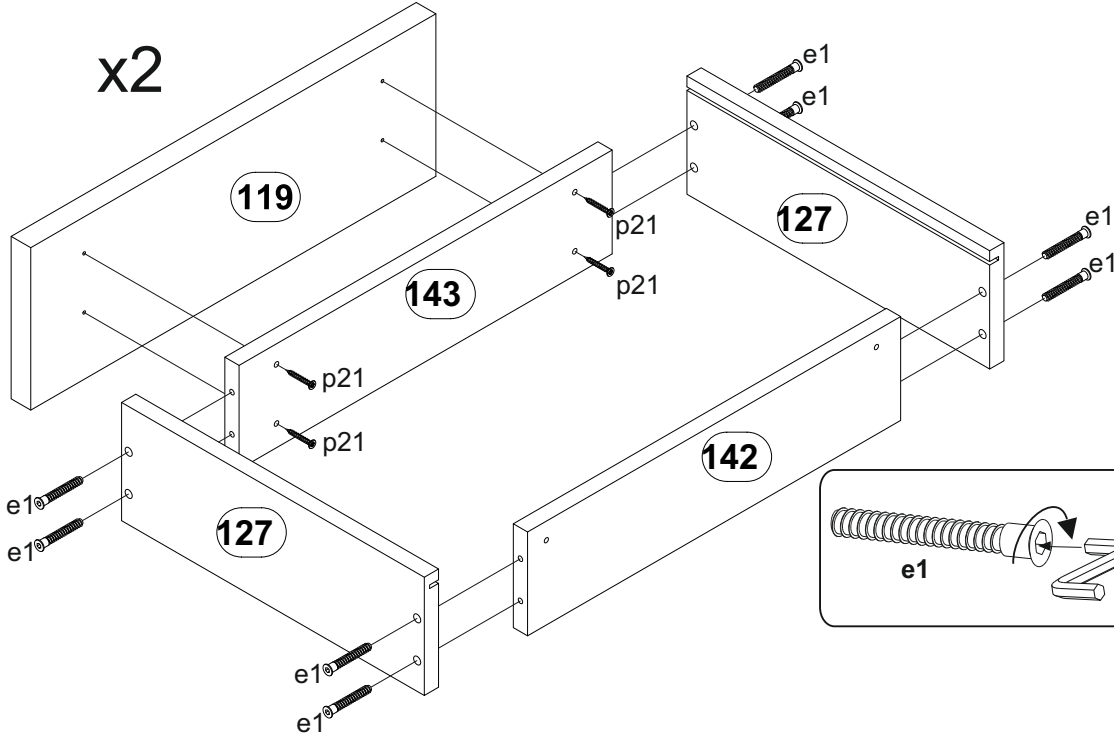

13

 7x50mm	 Ø4x30mm	 Ø3,5x16mm	 w117/3
e1 x16	p21 x8	p51 x12	w117/3 x4

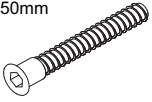

14

7x50mm 	Ø4x30mm 	Ø3,5x16mm 	
e1	x8 p21	x4 p51	x6 w117/3 x2

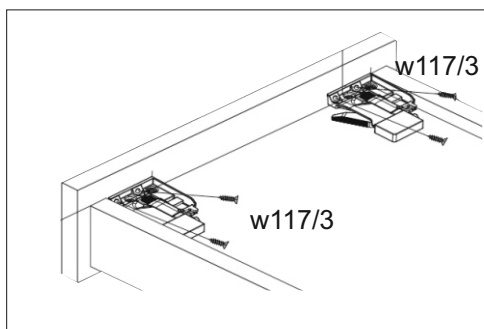
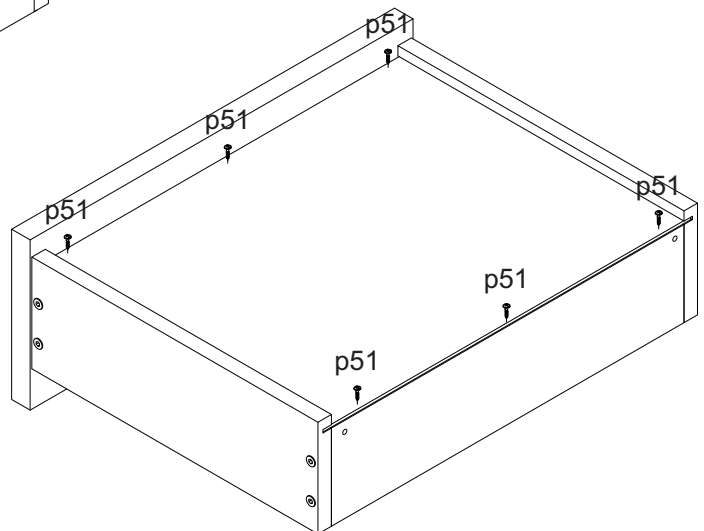
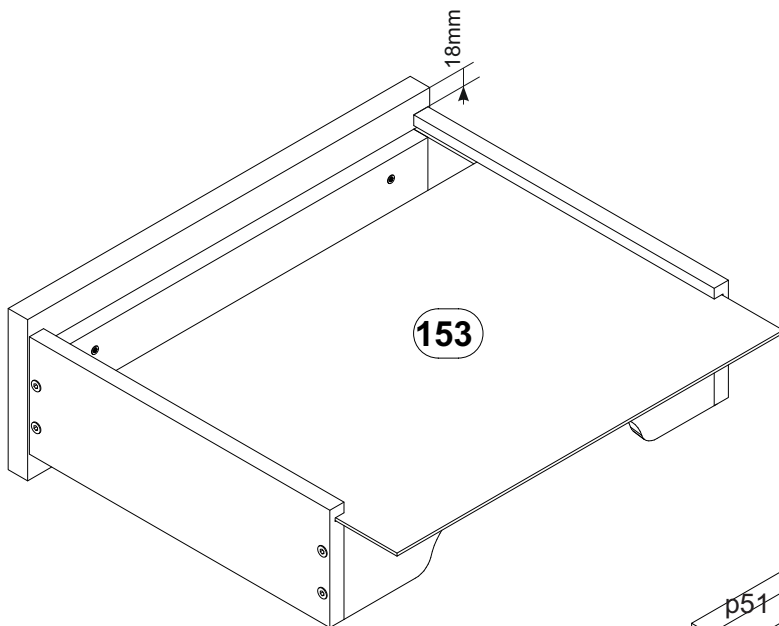
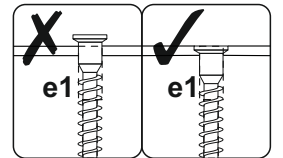
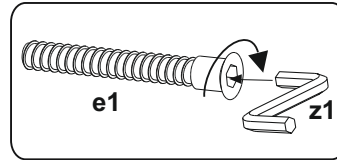
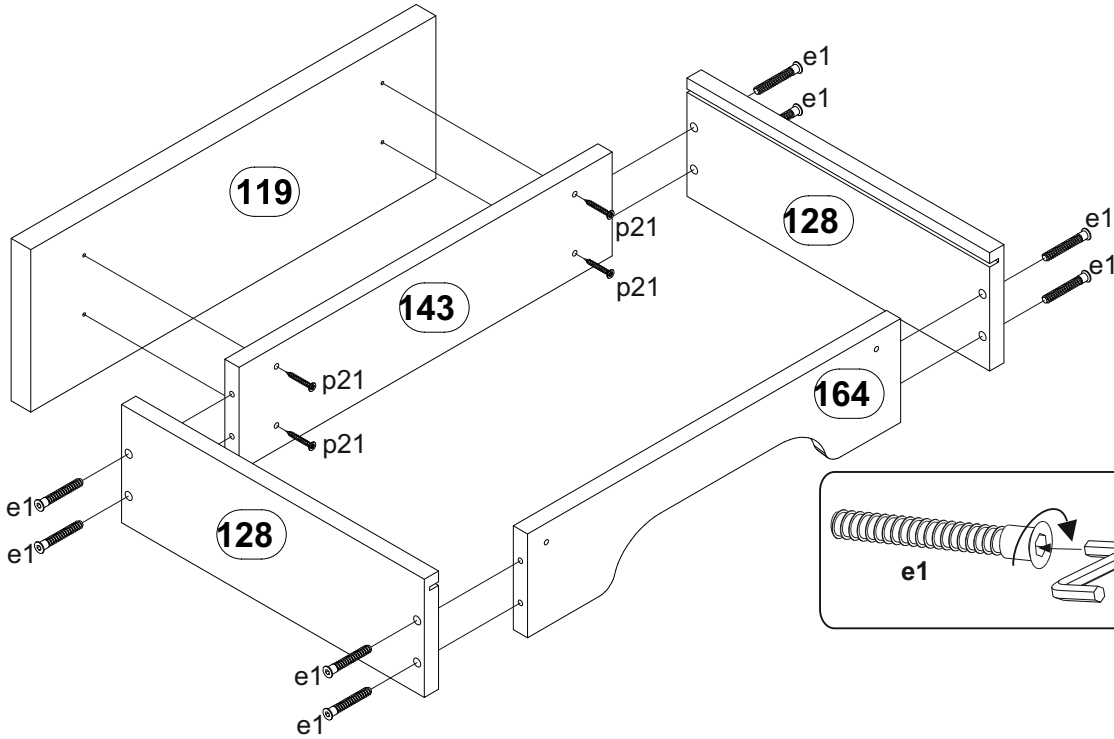

15 (Option)

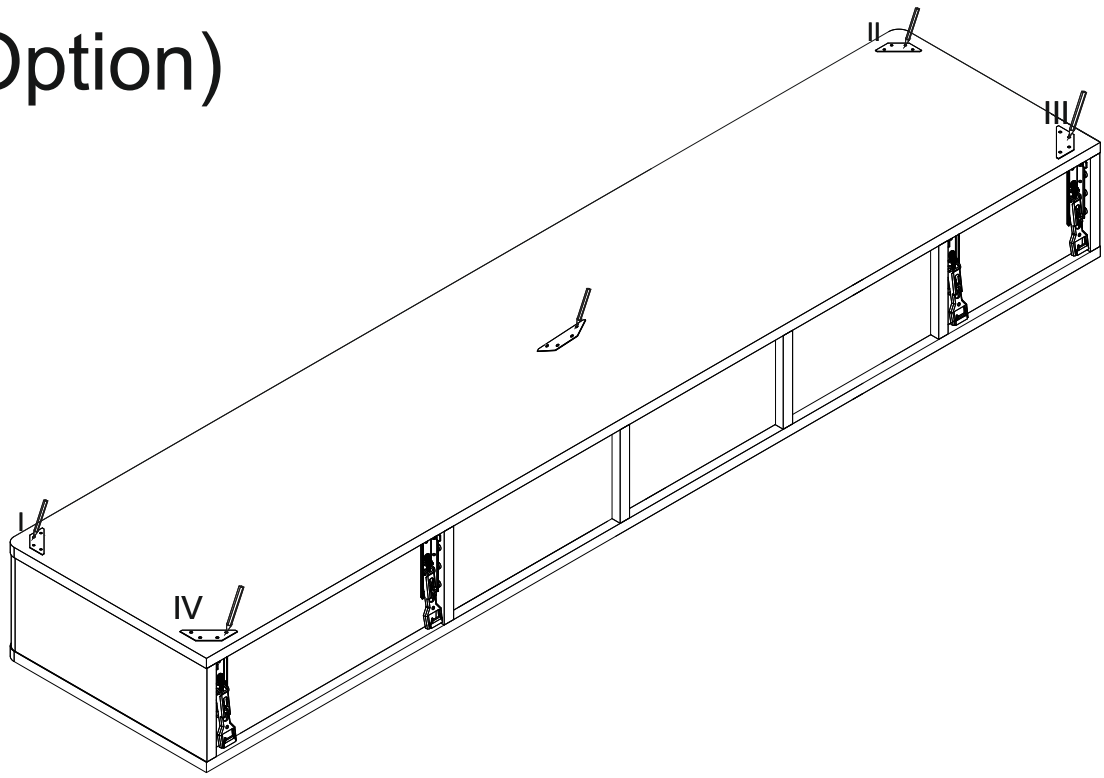

16 (Option)

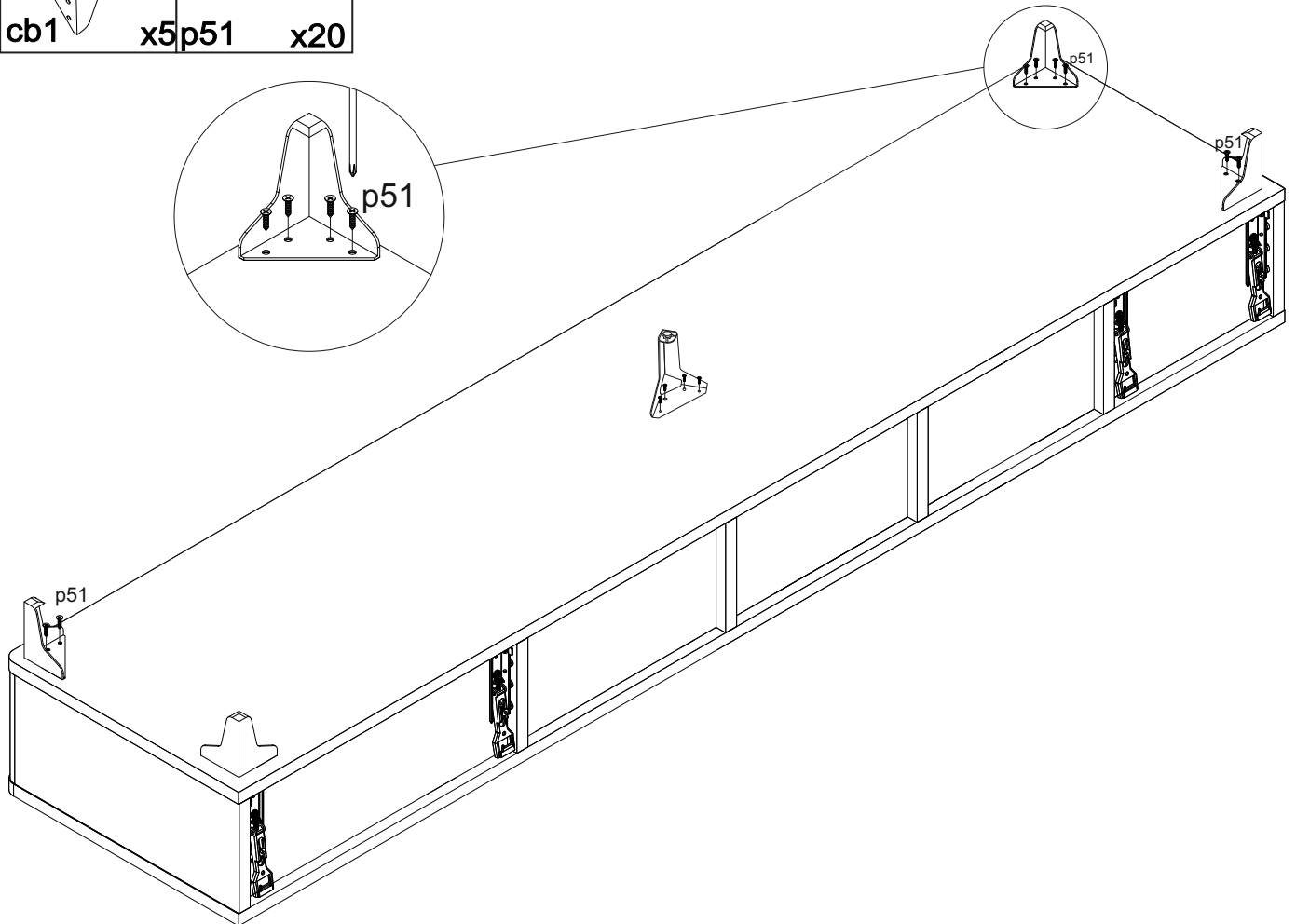
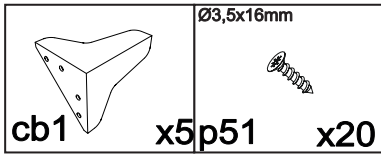

17

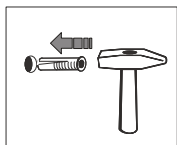
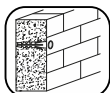
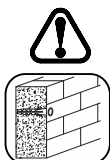
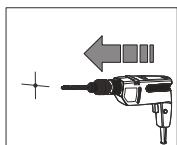
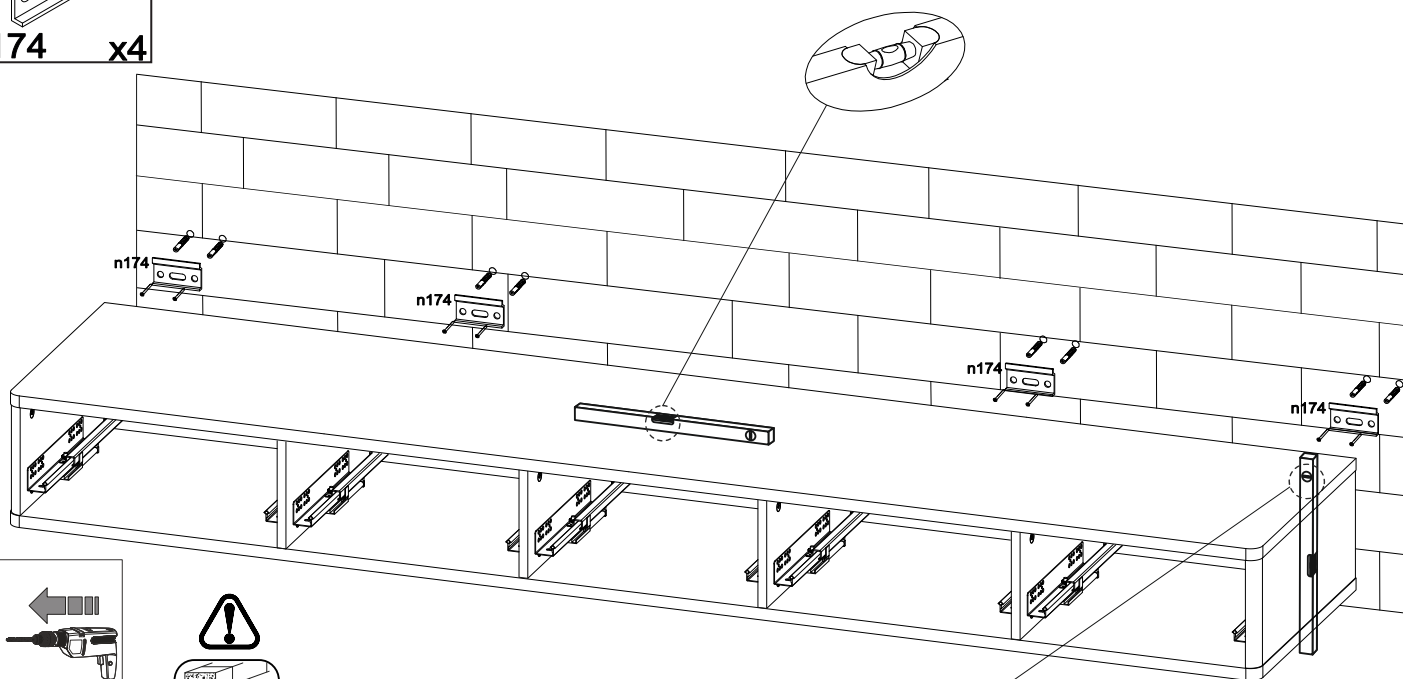
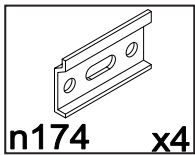

18 (Option)

