

SHTABE

ROYAL 5028

ROYAL 5029

5028

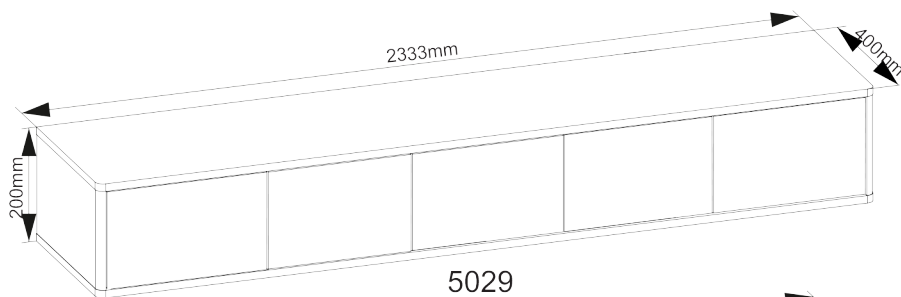

5029

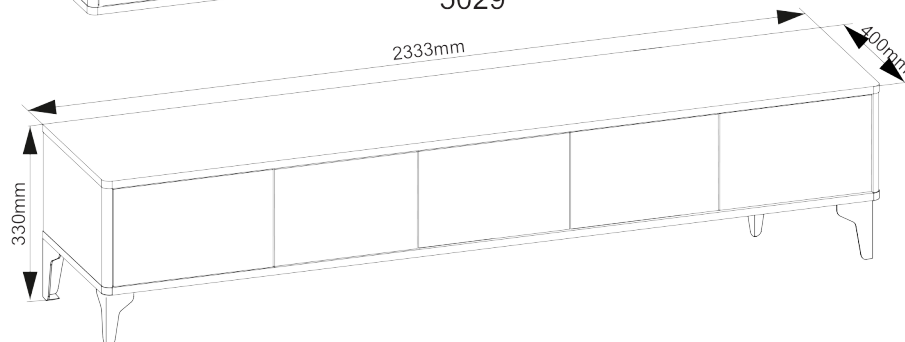

ТЕХПОДДЕРЖКА

DEUTSCH Fachkundige Montage erforderlich. Unsachgemäße Montage kann zu Unfällen führen. Da es viele verschiedene Wandmaterialien gibt, sind Schrauben für die Wandbefestigung nicht beige packt. Erkundigen Sie sich ggf. beim Eisenwarenfachhandel nach geeignetem Befestigungsmaterial.

ENGLISH Assembly should be carried out by a qualified person, because wrong assembly may lead to that the furniture will topple over and cause injury or damage. As wall materials vary, screws for fixing to wall are not included. For advice on suitable screw systems, contact your local specialised dealer.

FRANÇAIS Le montage doit être effectué par une personne compétente. Un montage mal effectué peut provoquer la chute du meuble et blesser quelqu'un. Les vis et ferrures pour fixer le meuble au mur ne sont pas incluses. Choisissez des vis et ferrures adaptées au matériel de votre mur. En cas de doute, demandez conseil à un vendeur spécialisé.

ITALIANO Il montaggio deve essere effettuato da una persona competente. Se non viene effettuato correttamente, il prodotto può ribaltarsi o cadere, danneggiando persone o cose. Poiché ci sono pareti di materiali diversi, le viti per il fissaggio alla parete non sono incluse. Per scegliere gli accessori di fissaggio adatti, rivolgetevi a un rivenditore locale.

ESPAÑOL Mantaje a realizar por montador autorizado, pues un montaje erróneo puede resultar en una caída del mueble, causando daños a personas o cosas. Como hay muchas clases de materiales de pared, no se incluyen los tornillos de montaje. Para sugerencias sobre sistemas de colocación adecuados, ponte en contacto con tu especialista más cercano.

PORTUGUES A montagem deverá ser realizada por uma pessoa qualificada, pois uma montagem incorrecta pode povocar a queda do móvel e causar lesões ou estragos. Como os materiais de parede variam, os parafusos para fixar à parede não estão incluídos. Para mais conselhos sobre o sistema de parafusos adequado, consulte o seu retalhista local especializado.

NEDERLANDS De montage dient te worden uitgevoerd door een vakbekwaam iemand. Foutieve montage kan ertoe leiden dat het meubel omvalt, waardoor er persoonlijk letsel of schade kan ontstaan. Omdat er veel verschillende wandmaterialen bestaan, zit er geen wandbeslag bijgesloten. Voor advies over geschikt wandbeslag, neem contact op met de vakhandelaar.

SVENSKA Montering ska utföras av kunnig person, då felmontering kan leda till att möbelen faller och skadar någon eller något. Eftersom det finns många olika väggmaterial, medföljer ej skruvar för vägginfästning. För råd om lämpliga skruvsystem, kontakta din lokala fackhandlare.

БЪЛГАРСКИ Необходим е монтаж от специалист. Неправилният монтаж може да причини злополуки. Тъй като има много различни стенини материали, винтовете за стенен монтаж не са приложени. При нужда се информирайте в специализираните железарски магазини за подходящия крепежен материал.

SLOVENSKO Potrebna je strokovna montaža. Nepravilna montaža lahko vodi do nezgod. Ker obstajajo različni stenski materiali, vijaki za pritrditev na zidu niso priloženi. Za ustrezen pritrditveni material se po potrebi pozanimajte v strokovni trgovini z železnino

DANSK Montering skal udføres af en kyndig person, da fejlmontering kan føre til at møblet falder og skader nogen eller noget. Eftersom der findes mange forskellige vægmateriale, medfølger der ikke skruer til vægmontering. Ønsker du råd omkring forskellige skruestystemer, kontakt din lokale faghandler.

ČESKY Montáž by měla být provedena kvalifikovanou osobou – nesprávné provedení může vést k převrhnutí nábytku a způsobit úraz nebo destrukci. Pro různé zdíci materiály nejsou šroubky a uchycení obsaženy v balení. O vhodném připevnění se porad'te s odborným prodejcem.

SLOVENSKY Montáž by mala byť prevedená kvalifikovanou osobou. Pri nesprávnej montáži môže dôjsť k pádu nábytku, a tým aj k prípadnému úrazu. Skrutky a uchytky na rôzne typy stien nie sú súčasťou balenia. Ak si nie ste istí, obráťte sa na kvalifikovanú osobu.

POLSKI Montaż powinien być przeprowadzany przez wykwalifikowaną osobę, ponieważ złe zmontowanie może spowodować zniszczenie mebla lub może wyrządzić szkodę domownikom. Ponieważ w każdym pomieszczeniu ściany mogą być wykonane z innego materiału, komplet nie zawiera żadnych wkrętów ani umocowań. Aby zasięgnąć porady w kwestii wyboru odpowiednich wkrętów skontaktuj się z lokalnym sklepem specjalistycznym.

MAGYAR Az összeszerelést ajánlatos képzett szakemberre bízni, mert a helytelen összeszerelés következtében a bútor felborulhat és sérülést okozhat. Mivel a fal anyaga lakásonként/otthononként eltérő lehet, a rögzítéshez szükséges csavarokat a csomag nem tartalmazza. A megfelelő csavar kiválasztásáért kérj tanácsot az áruházban a szakképzett személyzettől.

РУССКИЙ Сборка должна производиться специалистом, так как неправильная сборка может привести к опрокидыванию мебели, что может повлечь за собой ущерб или телесные повреждения. Так как материалы стен различаются, шурупы для фиксации к стене не прилагаются. Для выбора подходящих крепежных средств обратитесь в местный специализированный магазин.

ROMÂNĂ Necesită montaj de specialitate. Montarea necorespunzătoare poate cauza accidente. Deoarece există multe materiale diferite pentru pereți, șuruburile pentru fixarea pe perețe nu sunt incluse în ambalaj. Solicitați informații eventual de la magazinul specializat în articole de feronerie privind materialul de prindere adecvat.

HRVATSKI Potrebna stručna montaža. Nestručna montaža može dovesti do nesreća. Budući da postoje različiti zidni materijali, vijci za pričvršćenje na zid nisu uključeni. Raspitajte se npr. u željezarnji o prikladnim materijalima za pričvršćenje.

TÜRKÇE Uzman kişilerce montaj yapılması gereklidir. Usulüne uygun yapılmayan montaj kazalara yolaçabilir. Çok sayıda duvar malzemesi olduğundan duvara sabitleme vidaları beraberinde verilmemiştir. İcabi halinde demirden yapılmış araç gereç satan dükkanlardan uygun sabitleme malzemeleri hakkında bilgi alın.

עברית מומלץ להרכיב את המוצר ע"י איש מקצוע.

הרכבה לא נכונה עלולה לגרום לתאונות.

עקב השוני בסוגי הקירות, ערכת ברגים לא מצורפת.

לבחירת הברגים המתאימים יש להתייעץ עם בעל מקצוע.

Service • Dienstverlening • Serwis • Servis • Сервисная служба





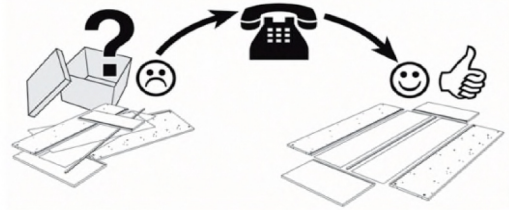
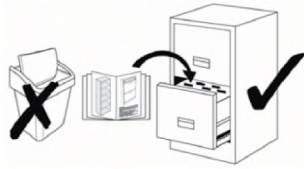



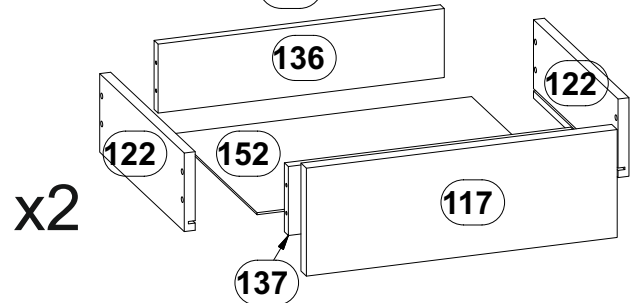
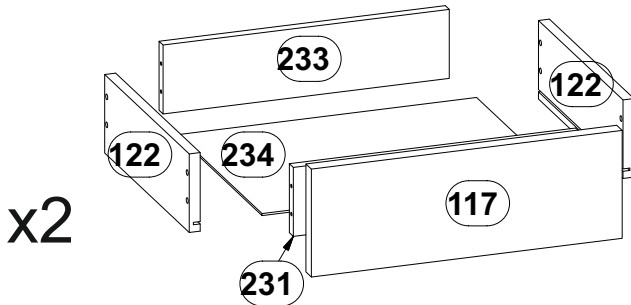
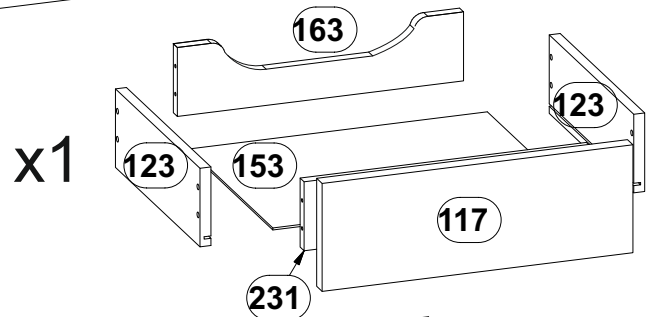
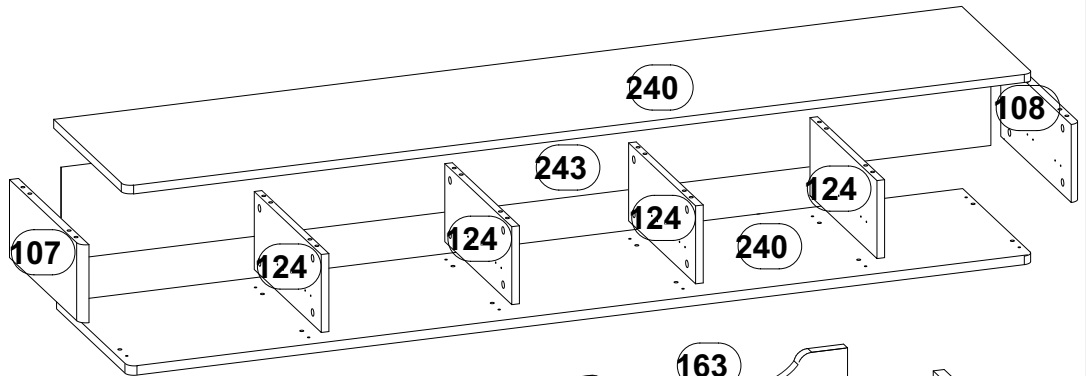

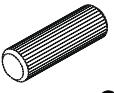

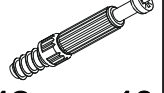

ТЕХПОДДЕРЖКА

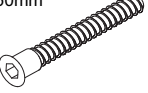

107	164	399	19	1x
108	164	399	19	1x
117	158	455	19	5x
122	340	115	16	8x
123	290	115	16	2x
124	163	354	16	4x
136	409	101	16	2x
137	409	101	16	2x
152	426	338	3	2x
153	417	288	3	1x
163	400	101	16	1x
231	400	101	16	3x
240	2333	400	16	2x
243	2292	163	16	1x
233	400	101	16	2x
234	417	338	3	2x

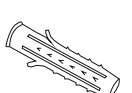
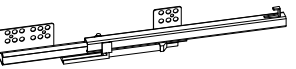
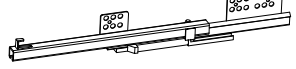
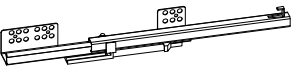
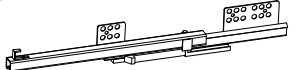

 f1	 r1	 r42	 cb1	 cb2	 p51	 j173
x34	x40	x40	x5	x1	x36	x8
 s2	 z1	 e1	 p38	 w117/3 x10	 p21	 f35
x40	x1	x46	x24	x16	x16	x8
 w117/L	 w117/P	 w116/L				
x4	x4	x1				
 w117/P						
x1						

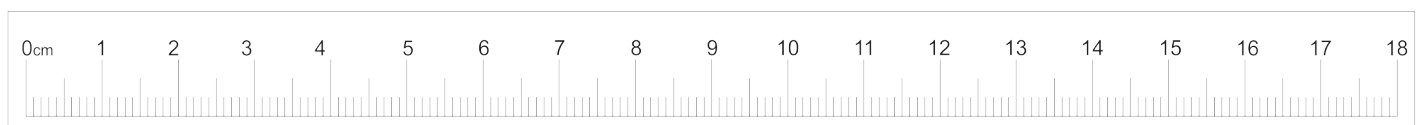

1

Перед сборкой консоли, приложите заднюю стенку консоли (деталь №243) к стене, и отметьте отверстия для ее крепления к стене.

Консольді жинамас бұрын, консольдің артқы қабырғасын (№243 бөлік) қабырғаға қойып, оны қабырғаға бекітуге арналған тесіктерді белгілеңіз.

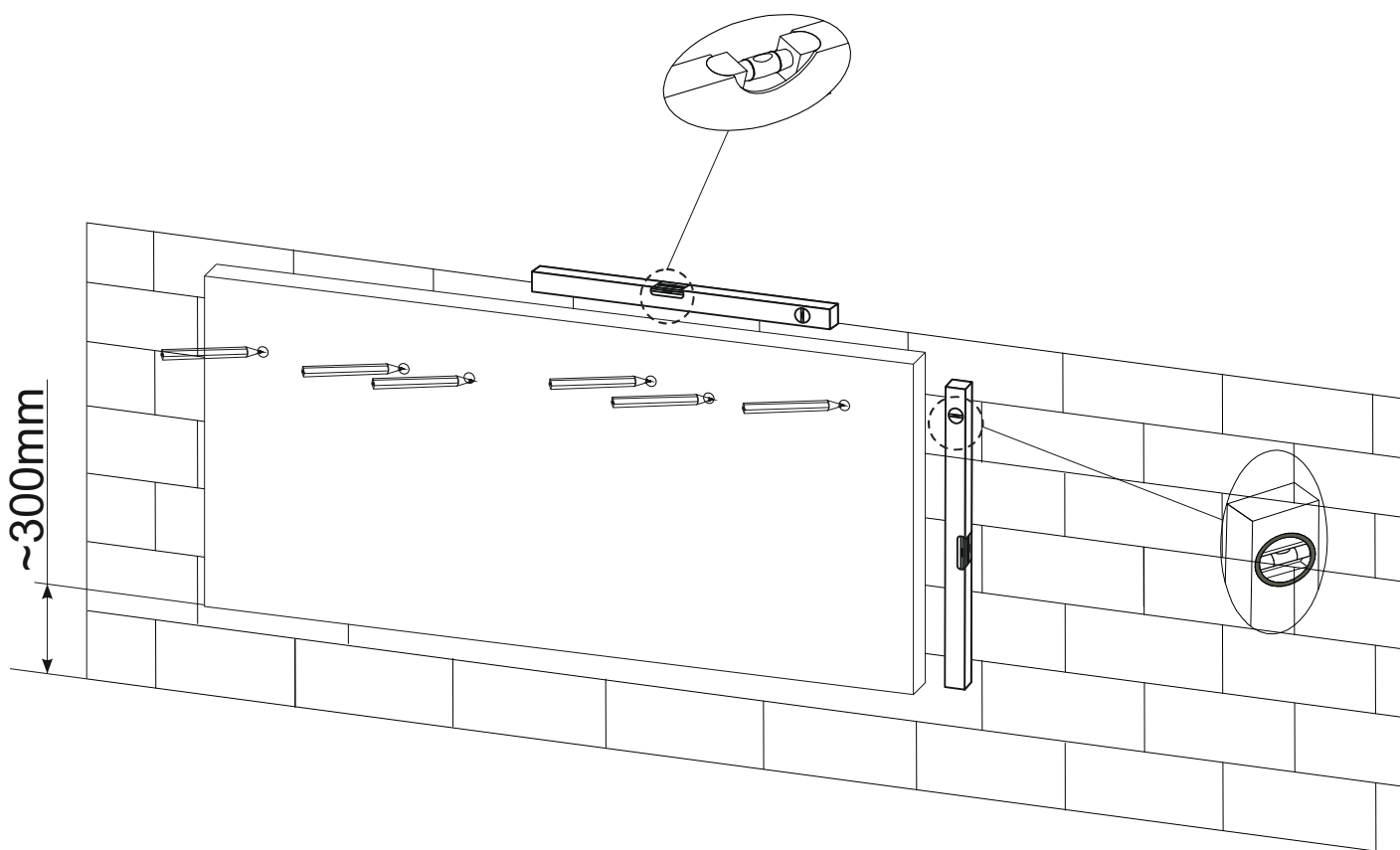

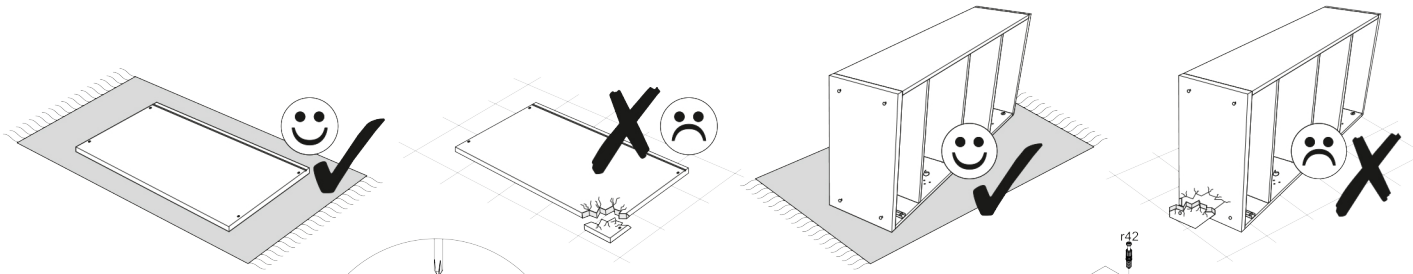

2

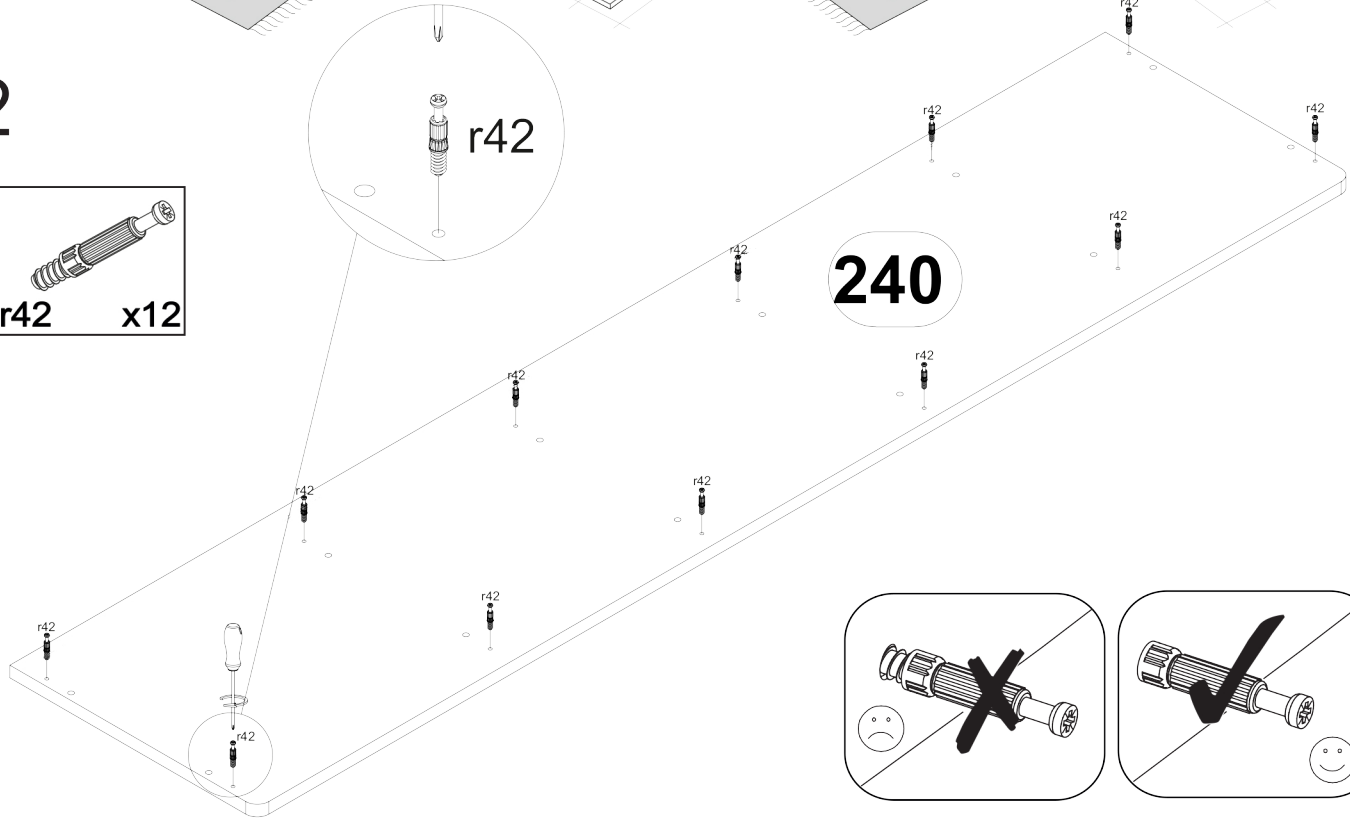
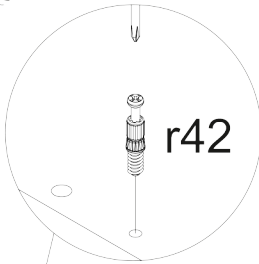
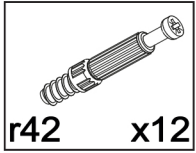

3

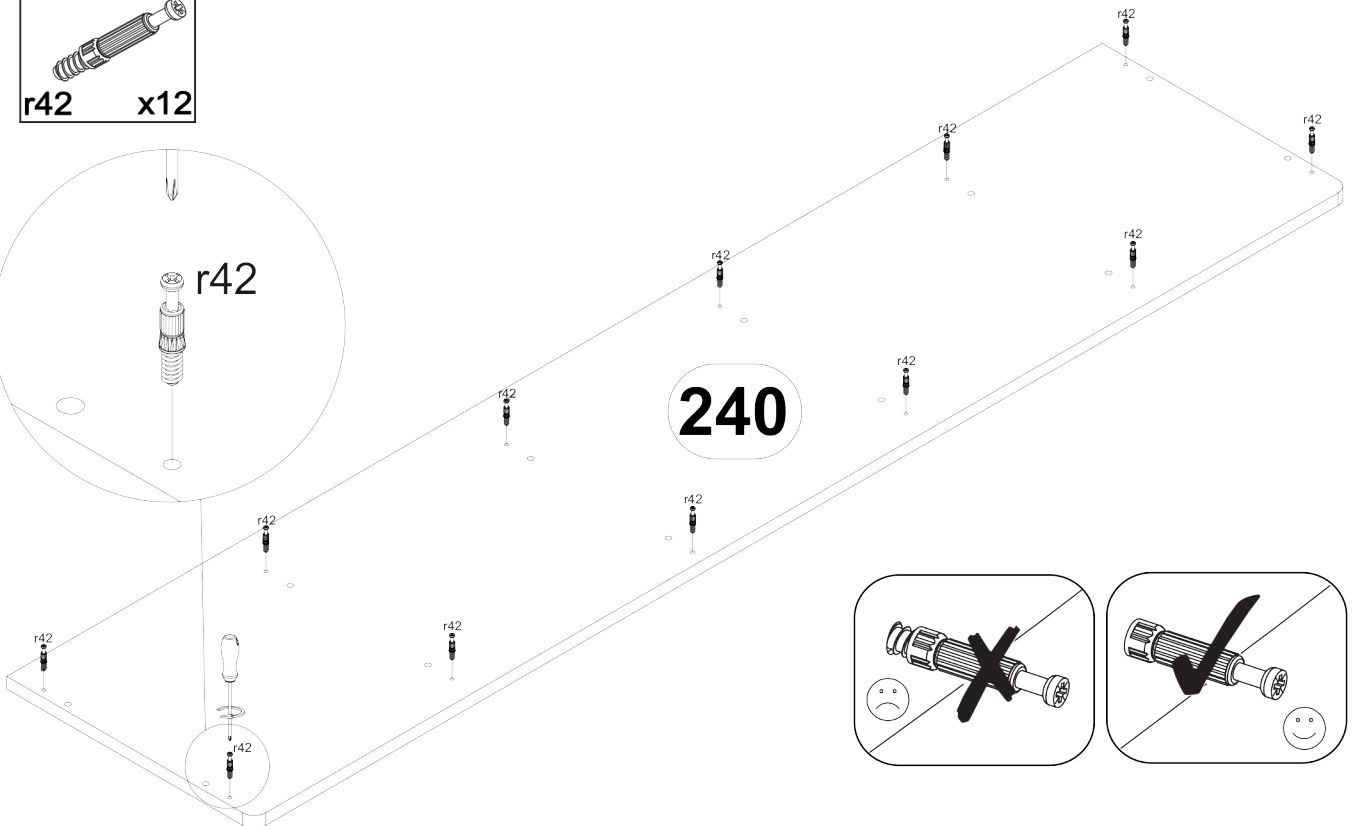
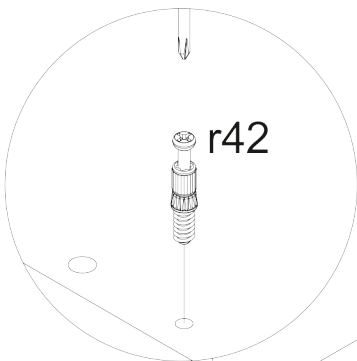
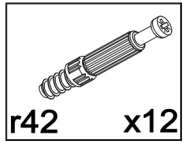

4

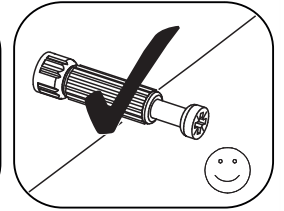
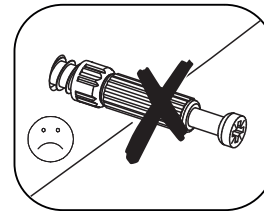
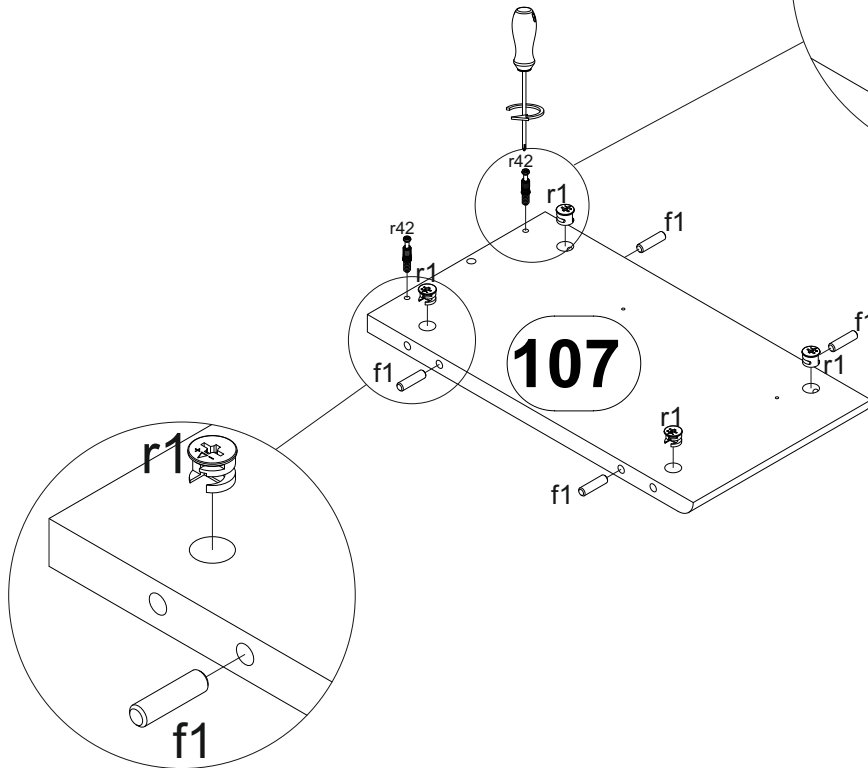
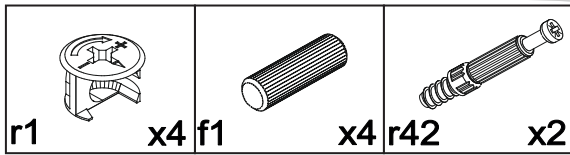

5

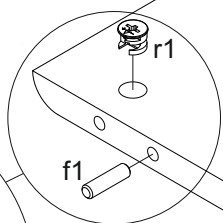
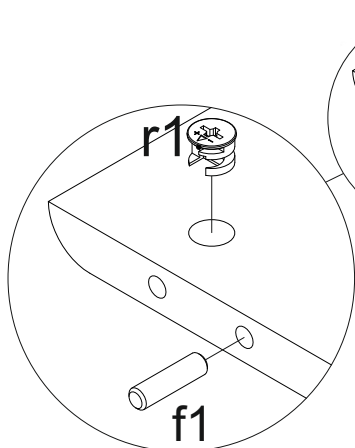
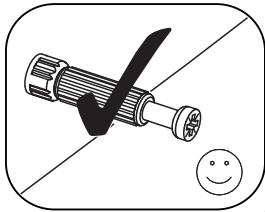
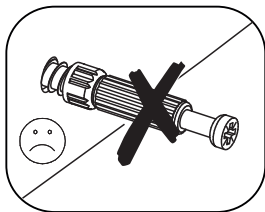
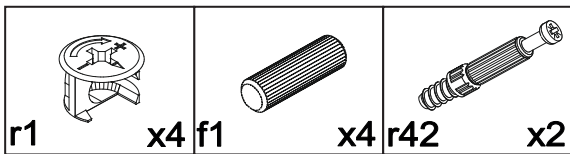

108

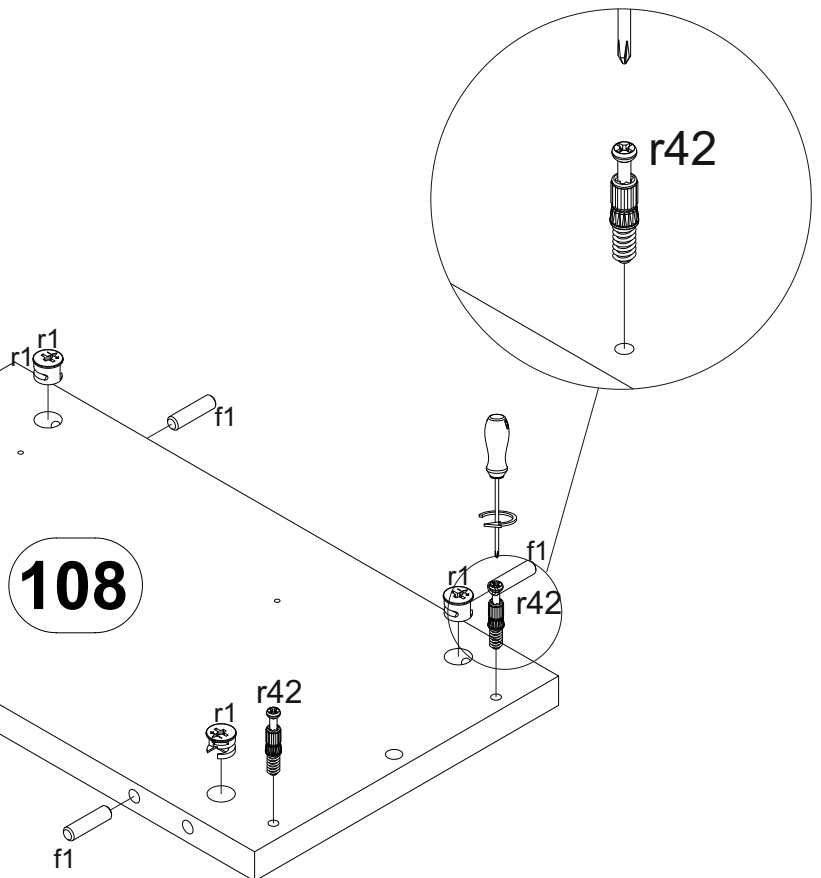

6

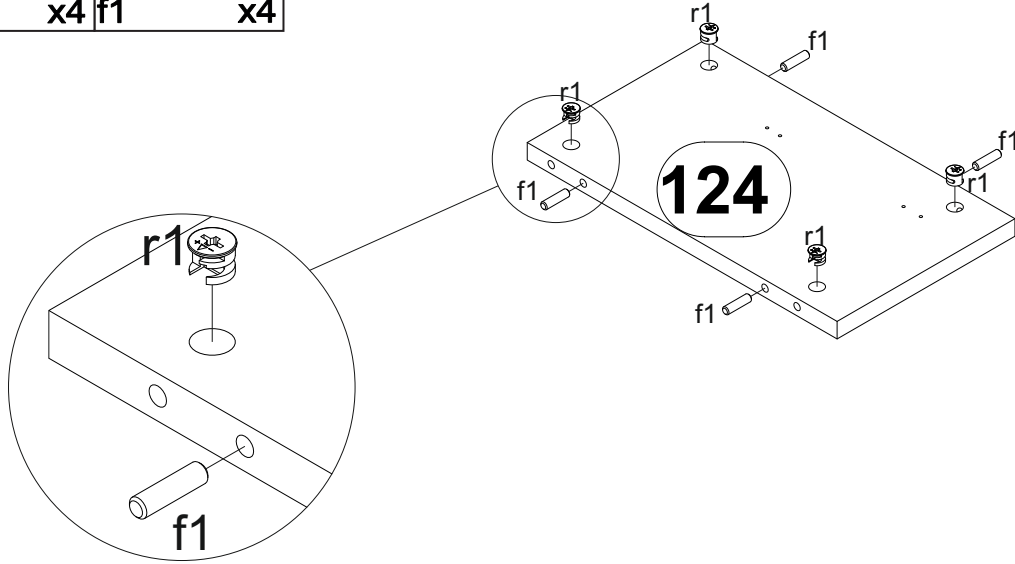
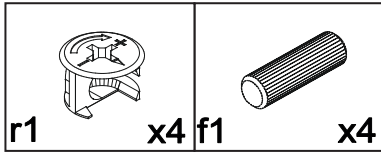

7

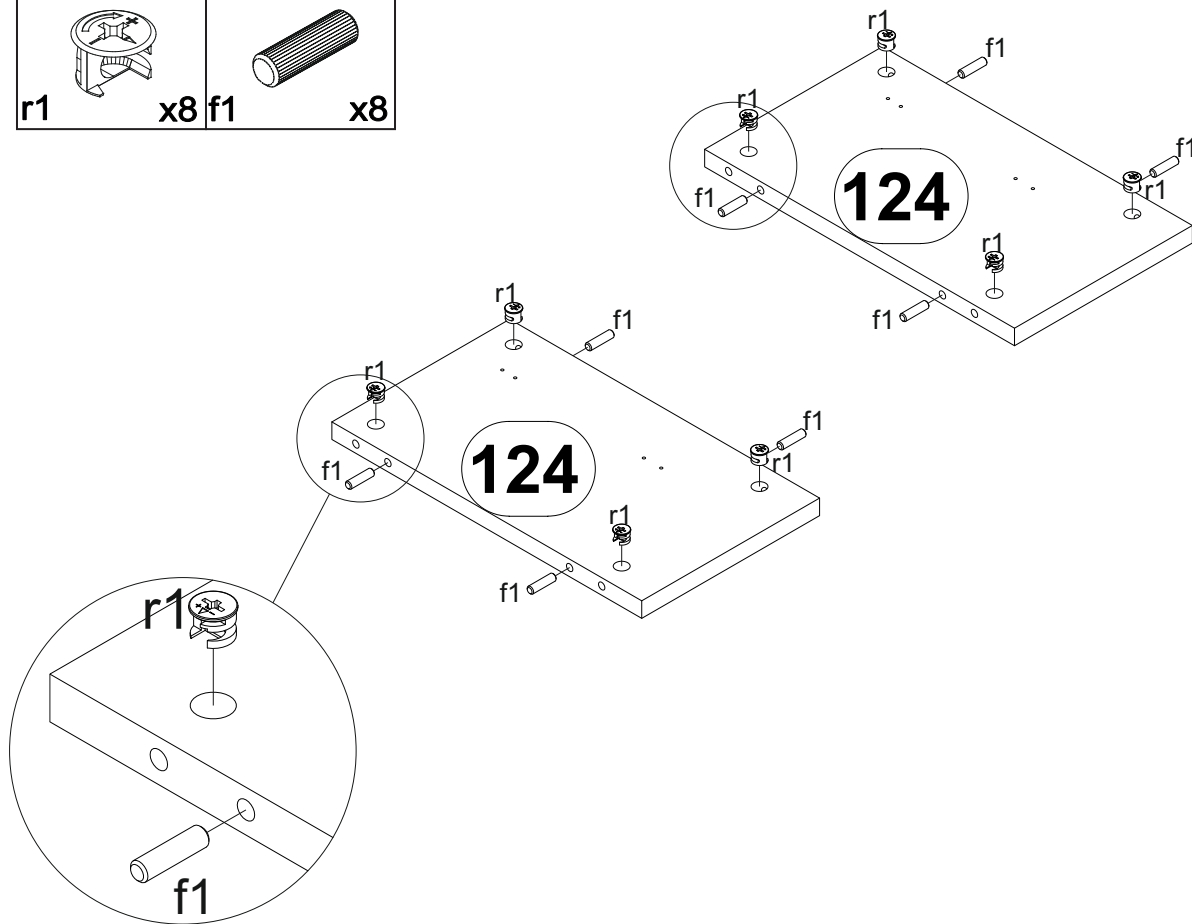
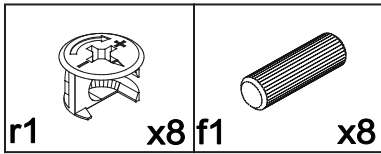

8

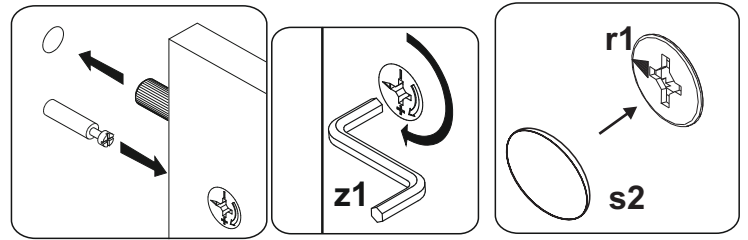
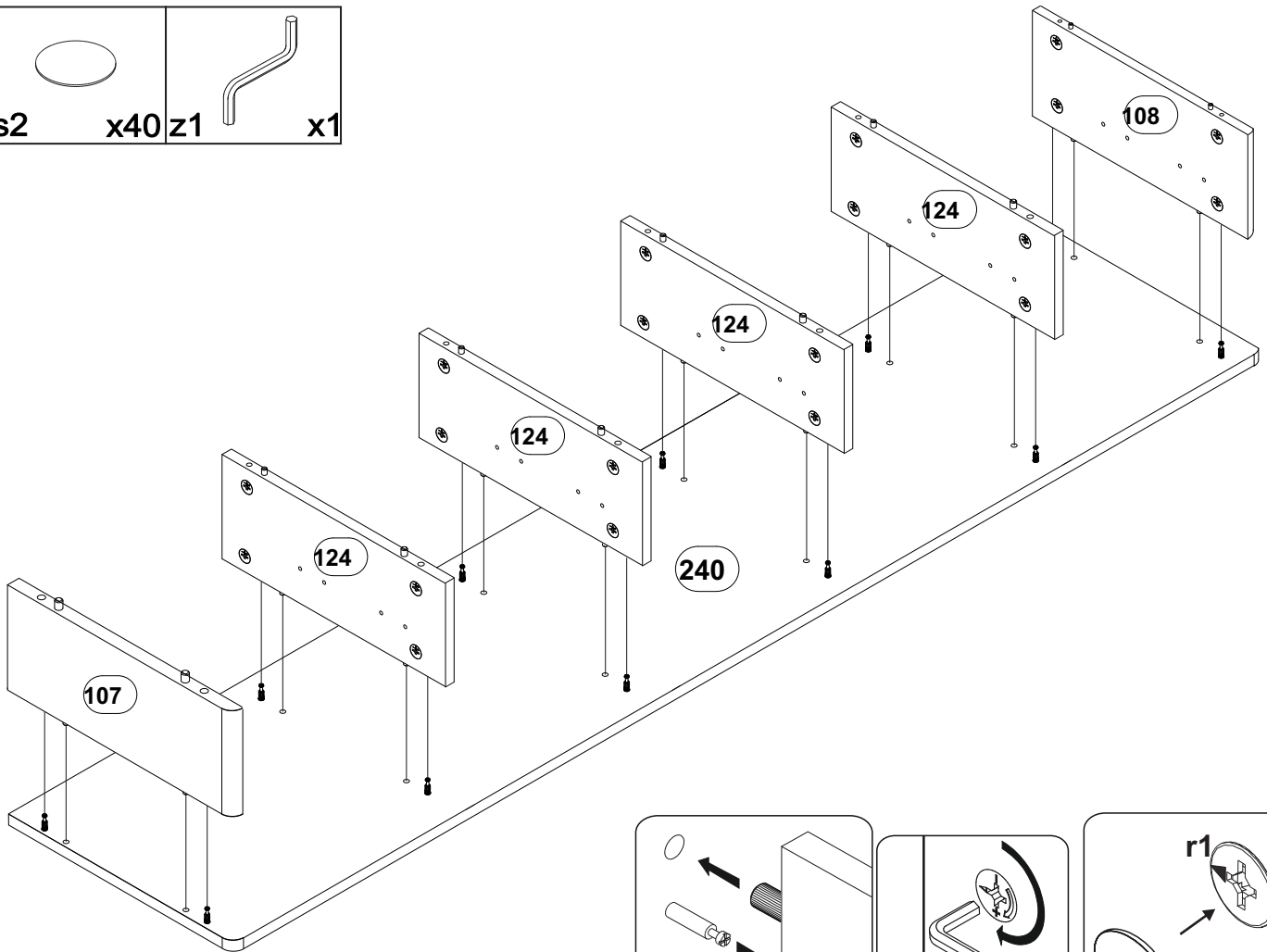
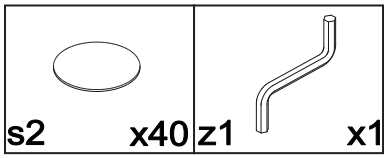



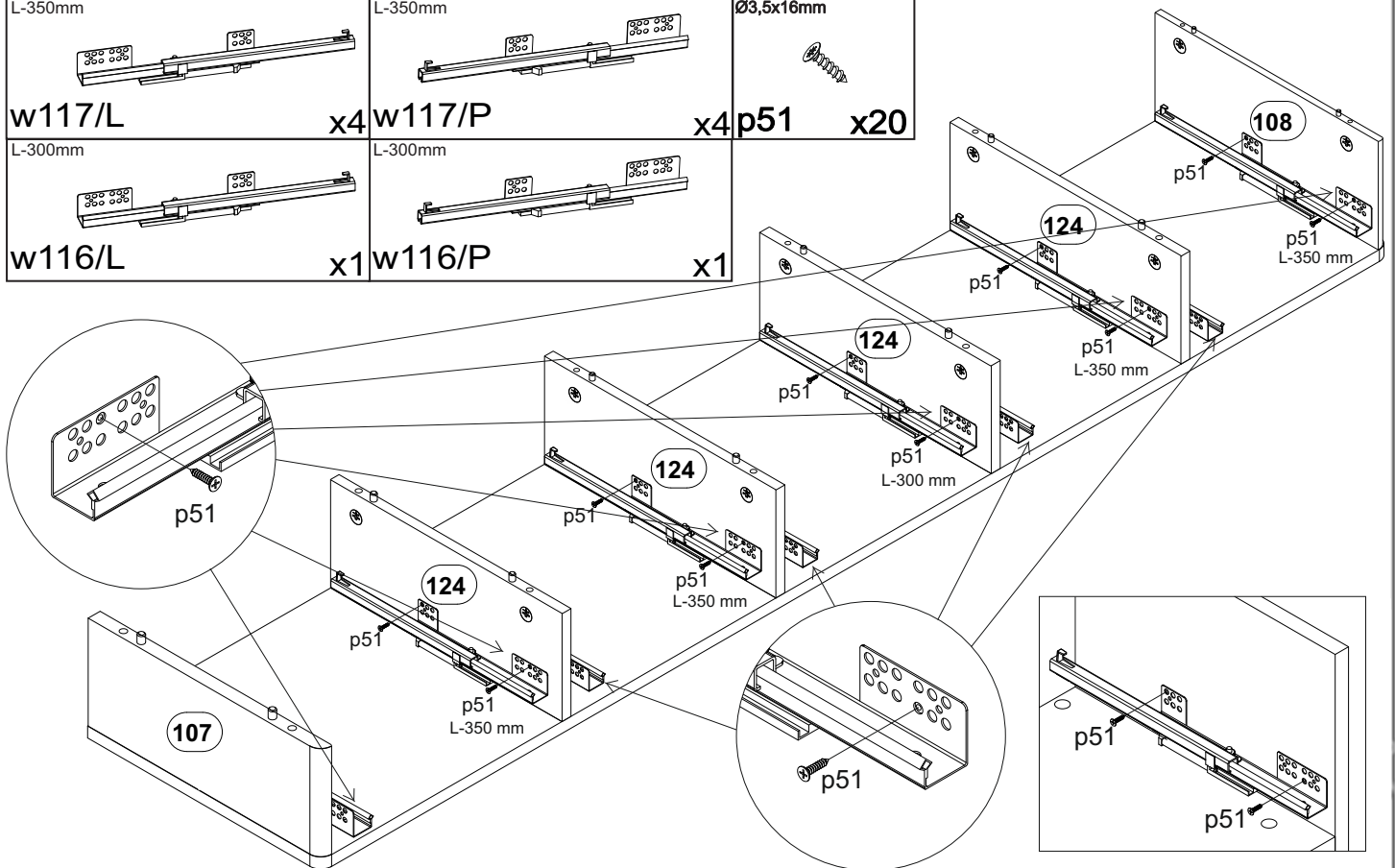
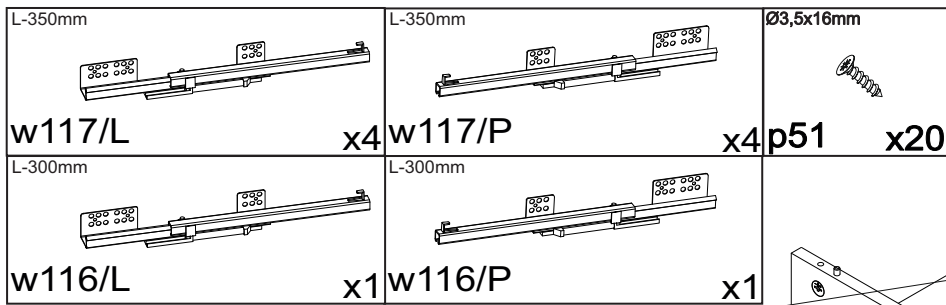

9

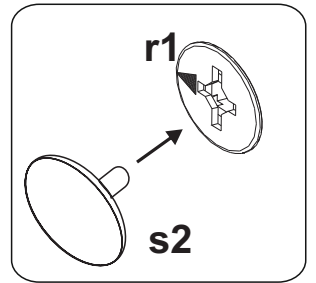
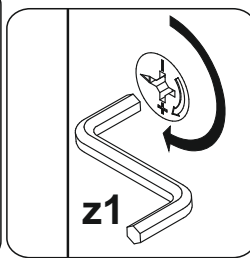
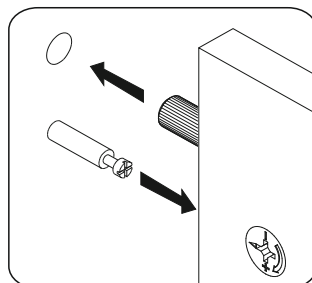
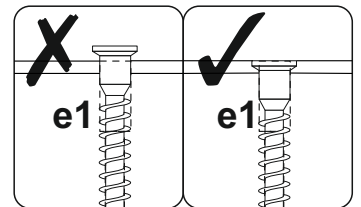
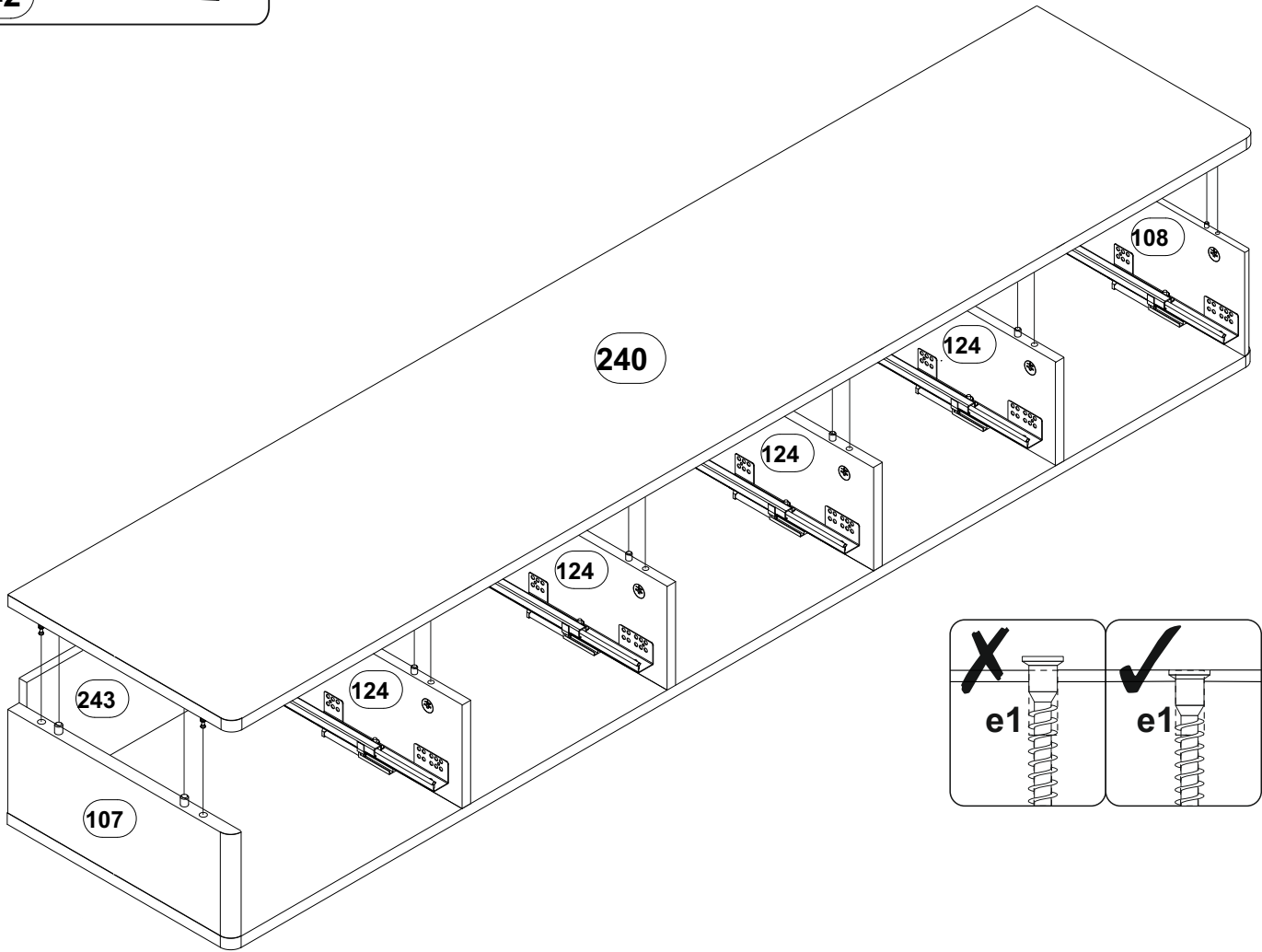
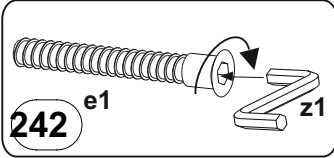
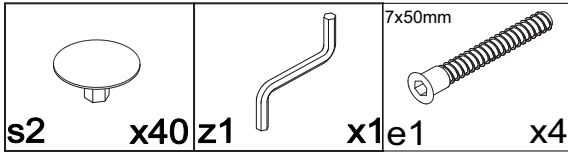

10

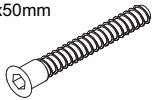



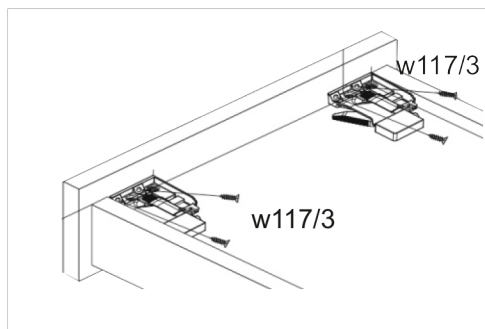
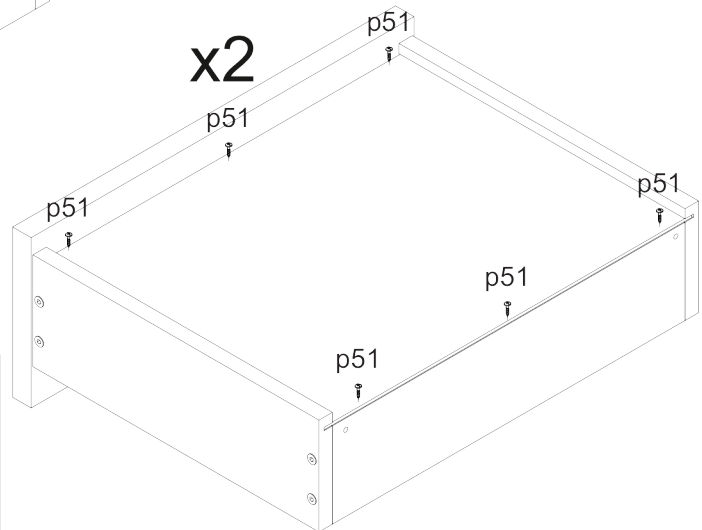
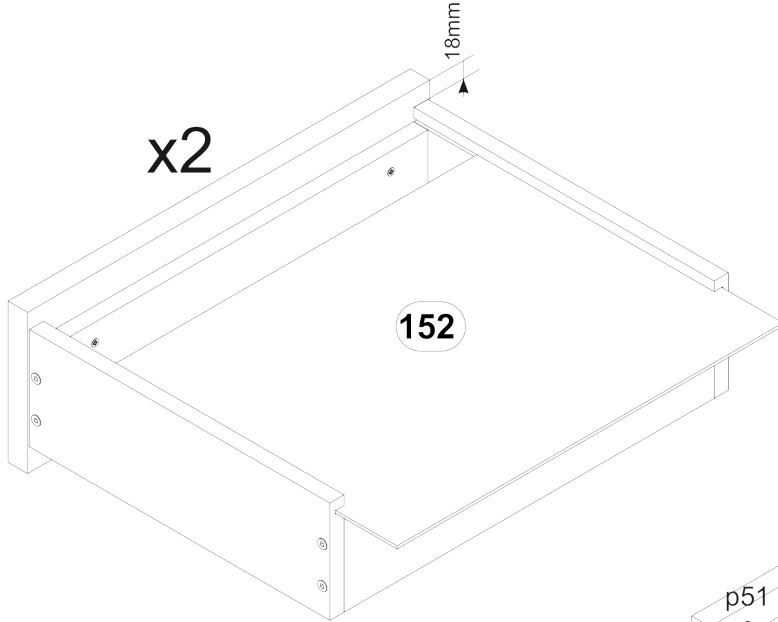
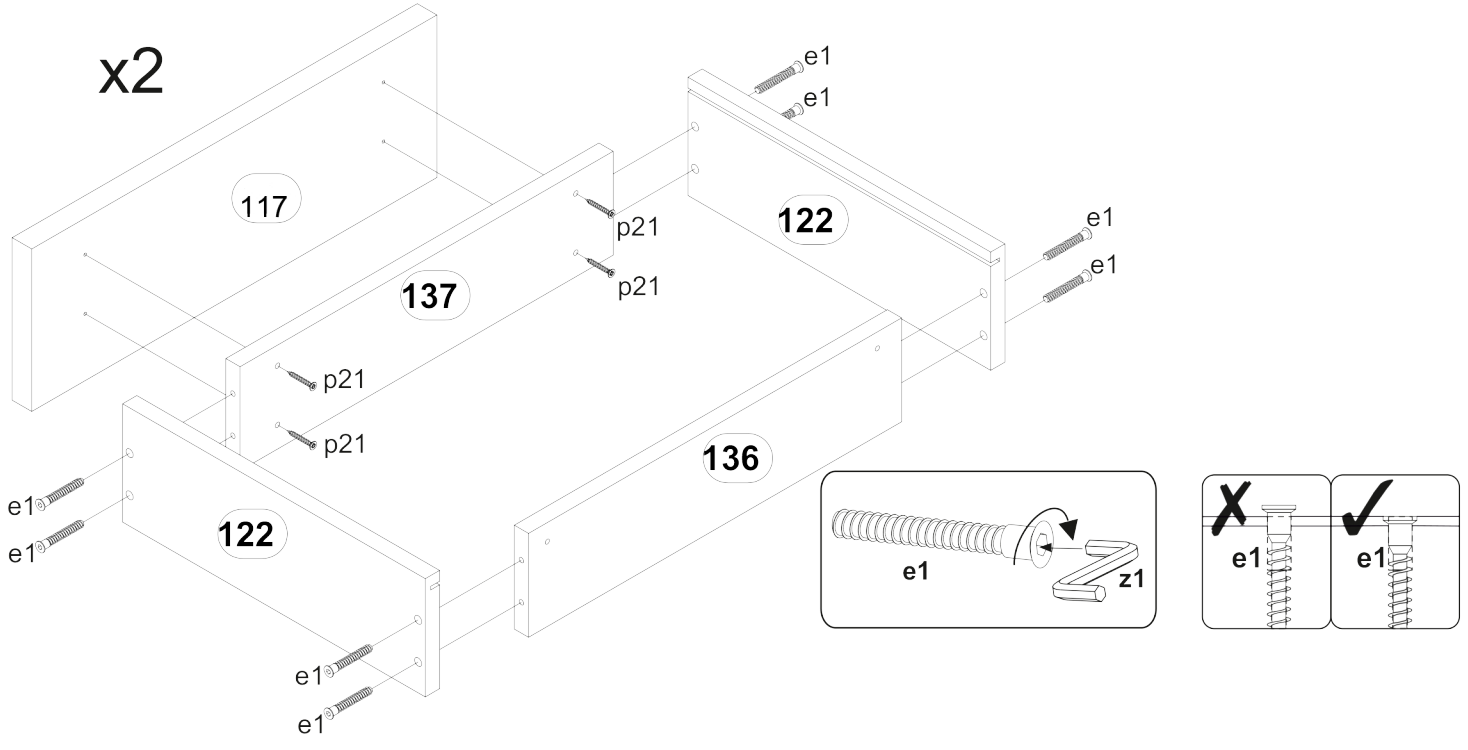

11

 7x50mm	 Ø4x30mm	 Ø3.5x16mm	 w117/3
e1	x16 p21	x8 p51	x12 w117/3 x4

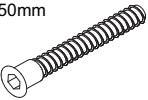



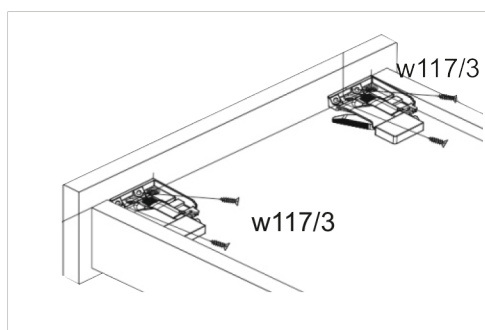
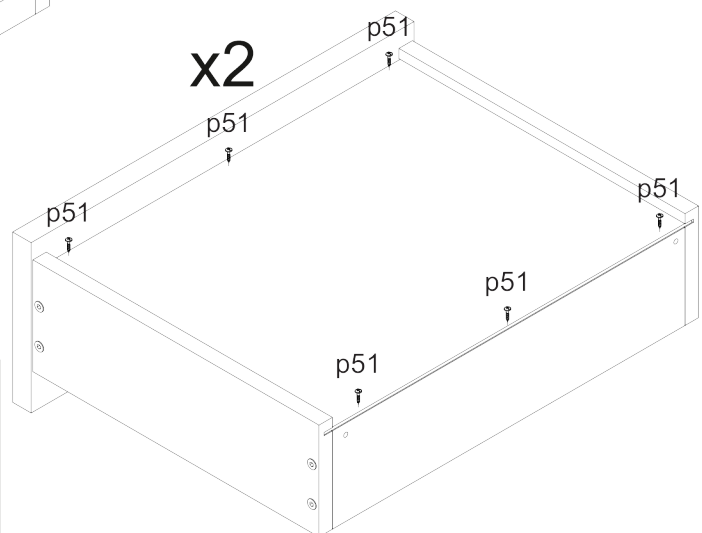
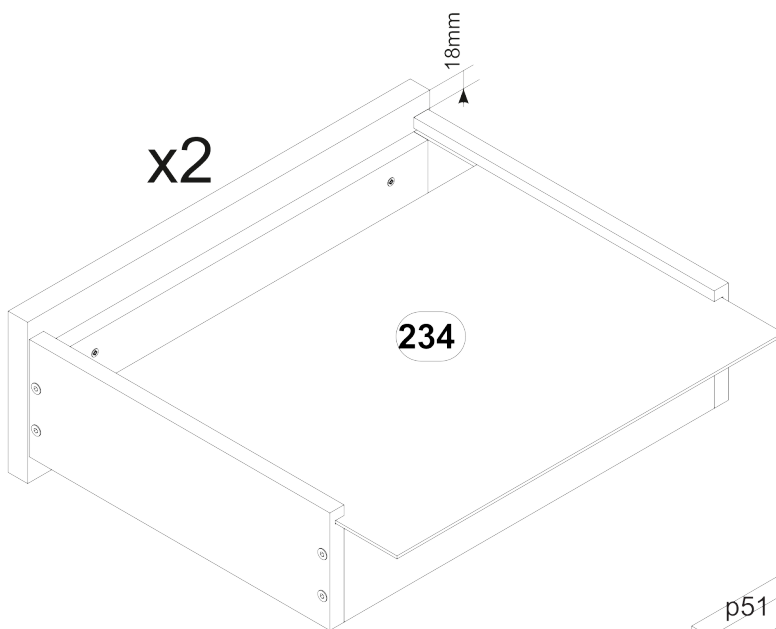
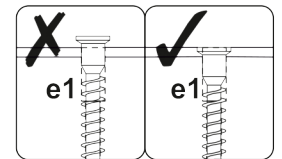
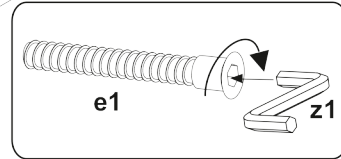
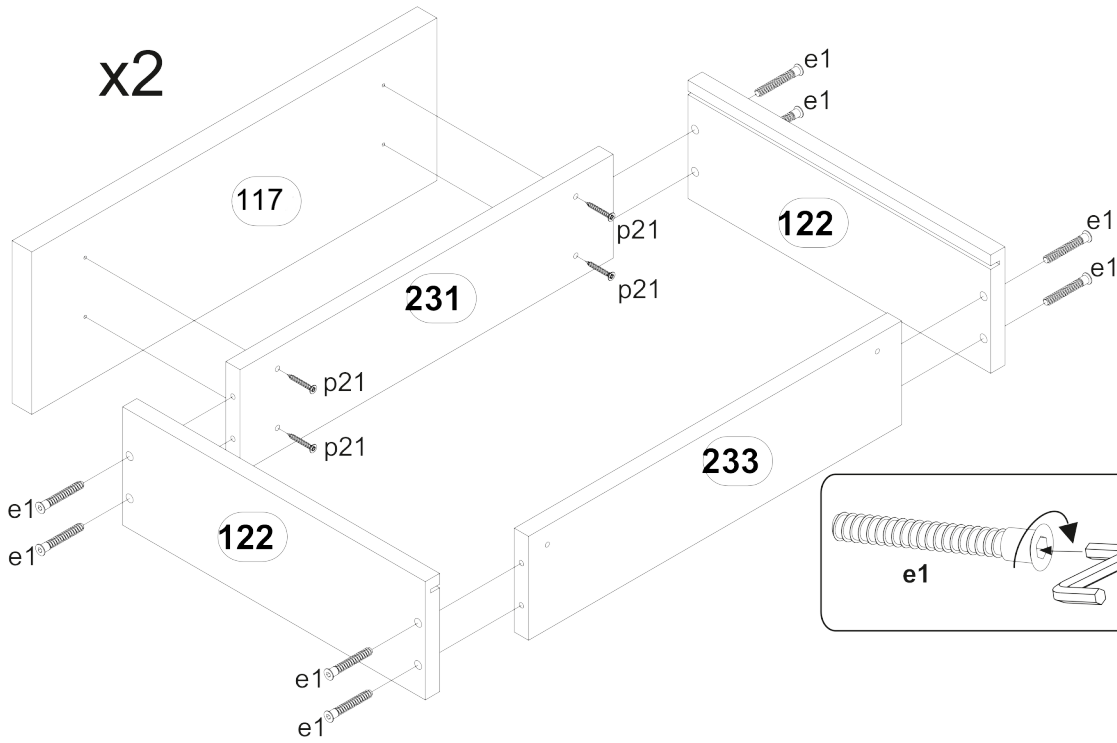

12

 7x50mm	 Ø4x30mm	 Ø3.5x16mm	 w117/3
e1	x16 p21	x8 p51	x12
			x4

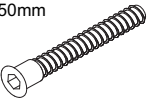

13

7x50mm 	Ø4x30mm 	Ø3.5x16mm 	
e1	x8 p21	x4 p51	x6 w117/3 x2

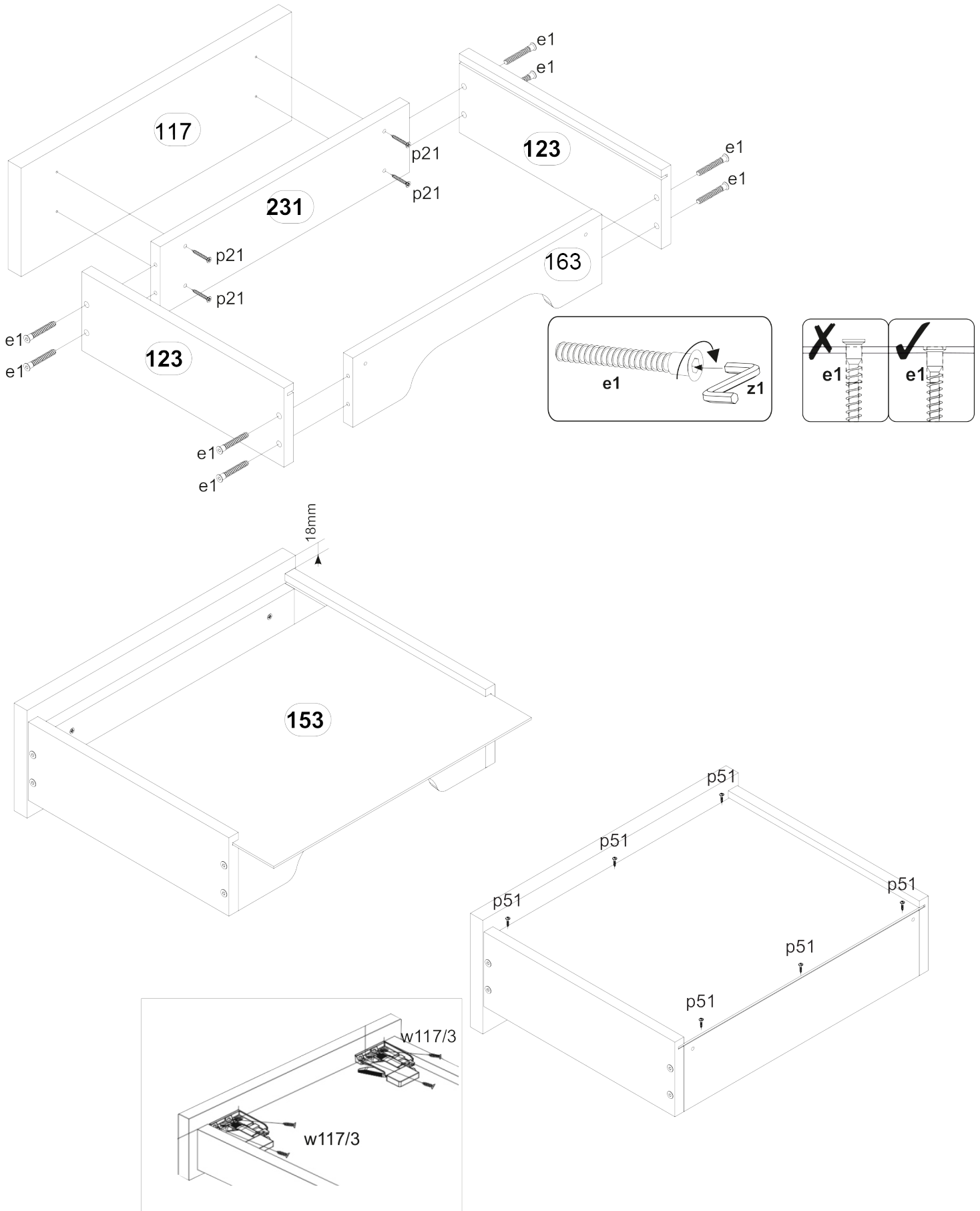

14 (Option 5028)

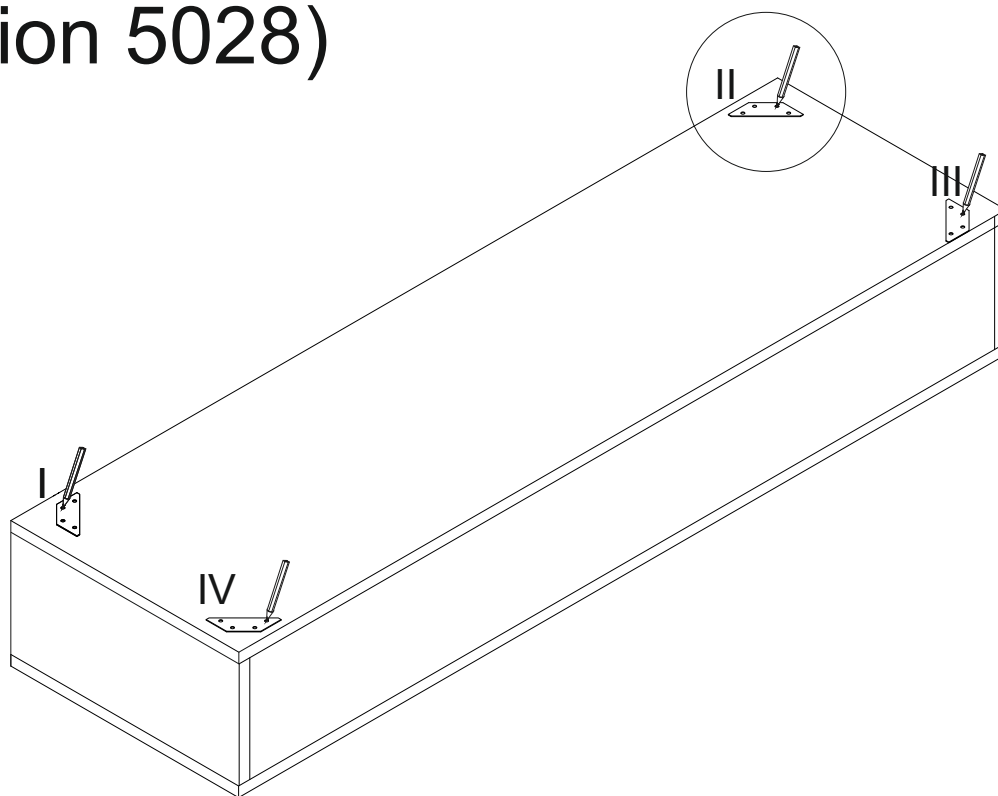
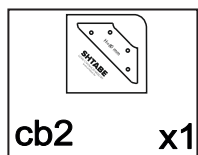

15 (Option 5029)

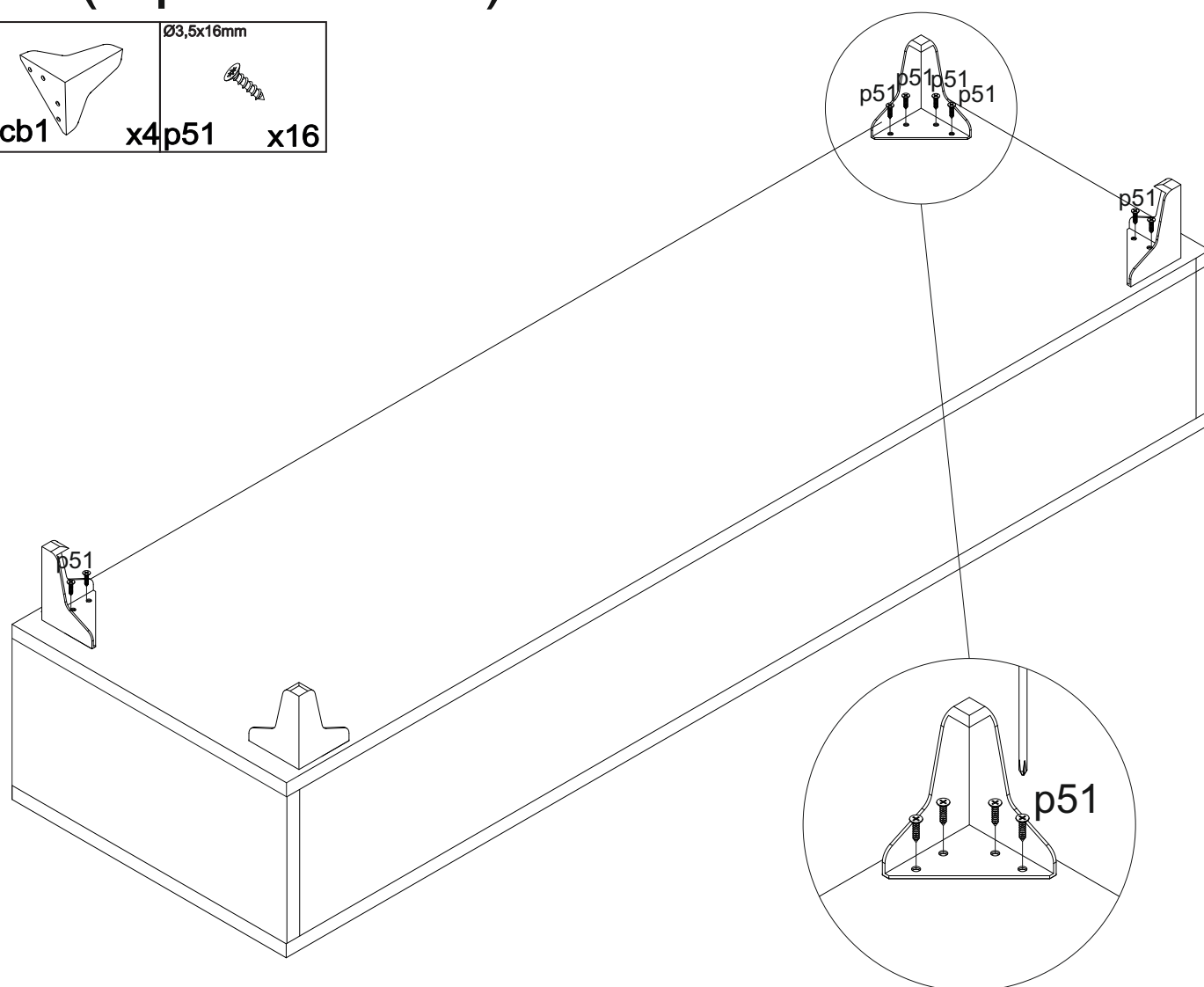
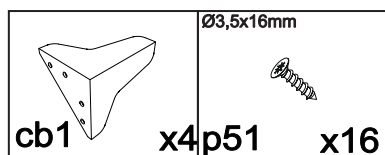

16

(Option 5028)

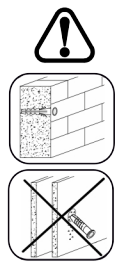
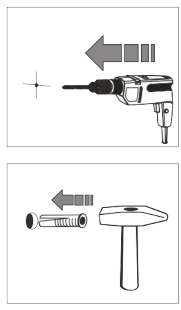
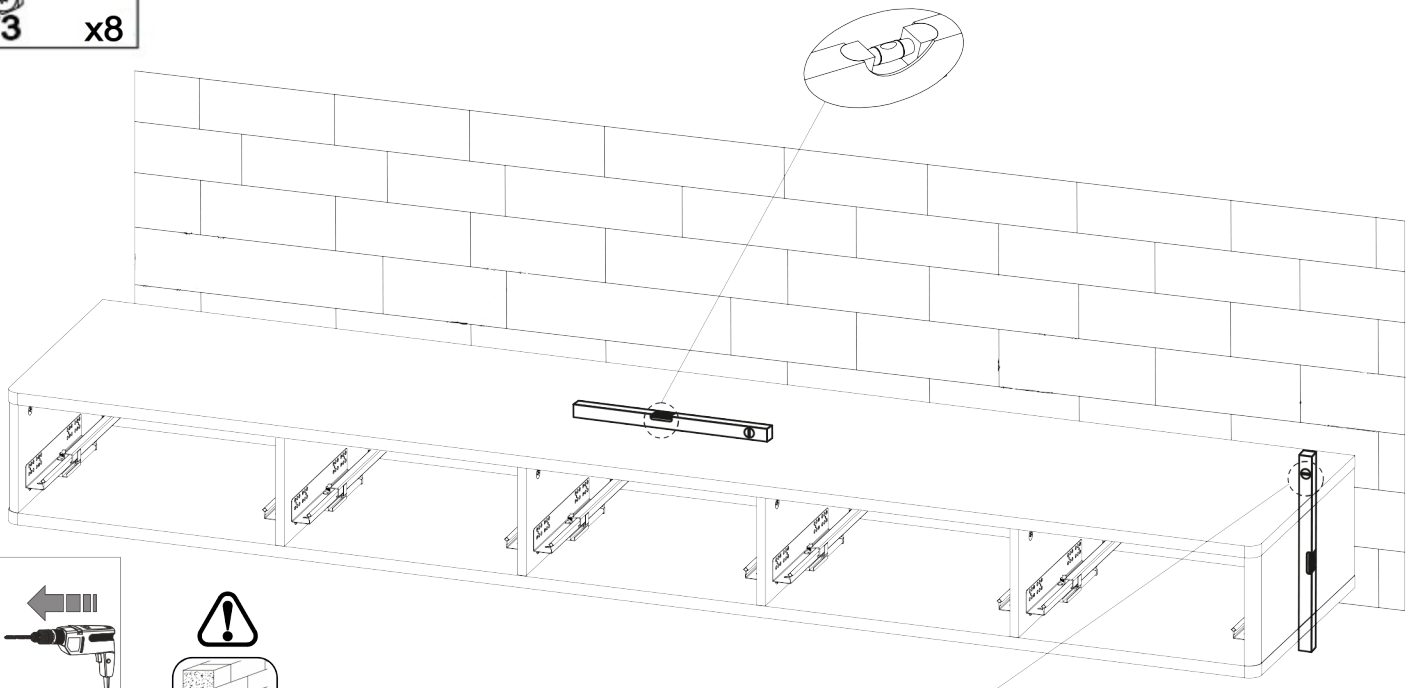
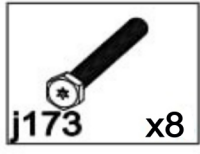

17

(Option 5029)

